



Fosse Green Energy

EN010154

9.28 AC Interference Risk Assessment on the Finaline Pipeline

VOLUME

9

Planning Act 2008 (as amended)

Regulation 8(1)(k)

Infrastructure Planning (Examination Procedure)

Rules 2010

28 April 2026

Planning Act 2008

The Infrastructure Planning (Examination Procedure) Rules 2010

Fosse Green Energy
Development Consent Order 202[]

9.28 AC Interference Risk Assessment on the FINAline Pipeline

Regulation Reference	Regulation 8(1)(k)
Planning Inspectorate Scheme Reference	EN010154
Application Document Reference	EN010154/EXAM/9.28
Author	Fosse Green Energy Limited

Version	Date	Issue Purpose
Rev 1	28 April 2026	Deadline 5

Table of Contents

1.	Summary.....	1
2.	AC Interference.....	2
3.	Modelling.....	4
3.1	GET OHL 4ZM (West Burton – Bicker Fen).....	4
3.2	Finaline Pipeline	6
3.3	Fosse Green Energy Circuit	8
3.4	HIFREQ Model	9
3.5	Modelled Scenarios.....	10
3.6	Soil Resistivity	11
4.	Results	12
4.1	Normal Operation Scenario	12
4.2	Fault Scenario	25
5.	Conclusion	30
5.2	Normal Operation Scenario	30
5.3	Fault Scenario	31
6.	References.....	32
	Appendix A Soil Resistivity Data	33
	Appendix B Soil Resistivity Ground Investigation Report	40
	Appendix C Finaline Crossing Specification	41
	Appendix D Finaline Crossing Indicative Drawings	43

Tables

Table 1 – Current density and a.c. Voltage limits on Finaline	3
Table 2 – Relationship between soil resistivity and a.c. corrosion risk	3
Table 3 – Characteristics of conductors used to model 4ZM OHL.....	6
Table 4 – Pipeline coating characteristics.....	7
Table 5 – Pipeline conductor characteristics	7
Table 6 – 400 kV cable characteristics	8
Table 7 – Current density on Finaline (4ZM OHL, Normal Operation). (Positive chainage represents North of crossing, negative chainage represents South of crossing).....	14
Table 8 – Current density on Finaline (Fosse Green Energy circuit, Normal Operation). (Positive chainage represents North of crossing, negative chainage represents South of crossing).	19
Table 9 – Current density on Finaline (4ZM OHL and Fosse Green Energy circuit, Normal Operation). (Positive chainage represents North of crossing, negative chainage represents South of crossing).	24
Table 10 – SR1 soil resistivity data.....	34
Table 11 – SR2 soil resistivity data	36
Table 12 – SR3 soil resistivity data.....	38

1. Summary

- 1.1.1 This technical note presents the results of an alternating current (a.c.) interference study carried out for a proposed 400 kV underground cable circuit associated with Fosse Green Energy, following a request from Prax at Issue Specific Hearing 2 on 8 January 2026 and in its subsequent written representation.
- 1.1.2 The purpose of this report is to identify the potential risk of a.c. induced corrosion to the existing Finaline pipeline and any safety risk to maintenance / repair workers posed by the proposed 400 kV underground cable circuit.
- 1.1.3 The a.c. interference of the 400 kV cable circuit has been evaluated using the HIFREQ module of the CDEGS software suite.
- 1.1.4 Calculations suggest that the maximum Current Density on Finaline as a result of the existing overhead line (OHL) is already greater than the 30 Am⁻² threshold during a normal operating scenario. UKOPA/GPG/027 notes that the guidance in the latest standards is that at current densities in excess of 30 Am⁻² there is an a.c. corrosion risk.
- 1.1.5 Calculations predict that the maximum Current Density on Finaline as a result of, solely, the proposed Fosse Green Energy circuit is 0.0256 Am⁻² during a normal operating scenario. This is less than 0.1% of the 30 Am⁻² threshold.
- 1.1.6 The modelling demonstrates that the maximum Current Density calculated on Finaline is expected to decrease as a result of the proposed Fosse Green Energy circuit (due to a shielding effect by the Proposed Development when the current interacts with the current from the overhead line), albeit it will remain above the threshold for corrosion due to the impact from the existing overhead line.
- 1.1.7 During a fault scenario the calculated Touch Voltages on the pipeline are predicted to be within the permissible limit of 645 V based on BS EN 50122. In addition, it is noted that fault conditions are rare (e.g., in the order of once every several years). The health and safety risk to individuals maintaining or repairing the pipeline is considered very low based on the short duration of the repairs and frequency of the fault.

2. AC Interference

- 2.1.1 AC interference on new and existing pipeline systems forming crossings or parallelisms with buried power lines has been assessed in response to queries from Prax and its agents, BPA, related to electrical safety and a.c. corrosion on the existing Finaline pipeline. There is a phenomenon relating to cathodic protected pipelines due to the presence of alternating currents above defined limits, even though cathodic protection levels are satisfactory, which has the potential to lead to accelerated localised corrosion of a pipeline in certain circumstances.
- 2.1.2 There are three different methods of coupling between a.c. power lines and pipelines that can result in a.c. corrosion.
- Low frequency induction (LFI) due to pipelines and power lines in parallel for a significant distance.
 - Capacitive coupling due to pipelines in close proximity to overhead power lines, or if insulated power cables are in direct contact with each other.
 - Resistive coupling when current discharges from a power line cable to earth which can result in an increase Touch Voltage on the pipeline. Corrosion can occur during the short-term interference event.
- 2.1.3 In this assessment Current Density is used to determine a corrosion risk – not rms Voltage on the Finaline pipeline. Current Density is determined using Equation 1 (shown below) – this is explained in UKOPA-GPG-027 guidance (Ref 1).
- 2.1.4 It is noted that whilst a.c. Voltage on the Finaline pipeline is not considered as a sole determinant of a.c. corrosion risk it is considered in a fault scenario where Voltage on the pipeline is relevant for Touch Voltage concerns. See below for the maximum permissible Touch Voltage.

Equation 1

$$I = \frac{8V}{\rho\pi d}$$

I = current density Am^{-2}

V – AC voltage on pipeline

ρ = soil resistivity

d = defect diameter

- 2.1.5 **Equation 1** shows that the current density increases inversely with the defect diameter and is related to the soil resistivity.

- 2.1.6 The guidance in the latest standards is that at current densities in excess of 30 amps per metre squared (Am^{-2}) there is an a.c. corrosion risk, as explained in BS EN ISO 18086.
- 2.1.7 In accordance with Section 5.4.4 of ENA 41-24 the normal operating time of protection relays and breakers should be used for safety voltage calculations, rather than back up protection clearance times. NGET Technical Specification TS 1 states that the target total fault clearance time for all infeed at normal operation is 140 milliseconds (ms) at 400 kV. Table 8 of BS EN 50122 provides Touch Voltage limits for 0.1 and 0.2 s fault clearance times. The 0.2 s fault clearance time was chosen as the limit for Touch Voltage on Finaline. The Touch Voltage limit on Finaline is 645 V.
- 2.1.8 It is noted that the Touch Voltage limit stated in BS EN 50122 assumes a operatives will be wearing industry standard PPE comprising shoes of at least 1000 Ω resistance.
- 2.1.9 The current density and a.c. voltage limits are presented in Table 1.

Table 1 – Current density and a.c. Voltage limits on Finaline

Parameter	Limitation	Comment
AC current density on a 1cm ² coating defect	< 30 Am^{-2}	In accordance with UKOPA Good Practice Guide for AC Corrosion (UKOPA/GPG/027)
Touch Voltage (Pipeline)	645 V	In accordance with Table 8 of BS EN 50122 for a 0.2 s fault
Touch Voltage (Pipeline)	15 V	In accordance with UKOPA Good Practice Guide for AC Corrosion (UKOPA/GPG/027) for steady state
Coating Stress Voltage (Fault Condition)	3000 V	SP-0177-2014 for FBE coating

- 2.1.10 Soil resistivity relates to corrosion risk, as tabulated in Table 2. The lower the soil resistivity the higher the a.c. corrosion risk on the pipeline, if the pipeline is affected by a.c. interference. The soil resistivity at the pipeline burial depth provides an indication of the risk of a.c. corrosion.

Table 2 – Relationship between soil resistivity and a.c. corrosion risk

Soil Resistivity (Ωm)	AC Corrosion Risk
0 to 25	Very High
25 to 100	High
100 to 300	Medium
>300	Low Risk

3. Modelling

3.1 GET OHL 4ZM (West Burton – Bicker Fen)

- 3.1.1 The existing OHL that passes over Finaline carries the West Burton – Bicker Fen circuits (Identified as NGET OHL 4ZM). It is noted that a new substation is proposed near Navenby and the circuits that cross the Finaline will be referred to as West Burton – Navenby 1 and 2 in the future. However, for the purposes of this study the existing OHL nomenclature and characteristics are used. An exception is made when considering a fault scenario – in this case a prospective fault level for Navenby has been considered. This was done to assess the future a.c. corrosion conditions on the pipeline.
- 3.1.2 The OHL tower assumed for the modelling is illustrated in Figure 1a. Phase – phase and phase – ground clearances is presented in Figure 1b, with an assumed insulator length of 4.0 m. The crossing angle of the West Burton – Bicker Fen OHL was modelled as 58.9 °. A *.kml containing OHL and Tower positioning was obtained from National Grid Electricity Transmission (NGET) (Ref 2).

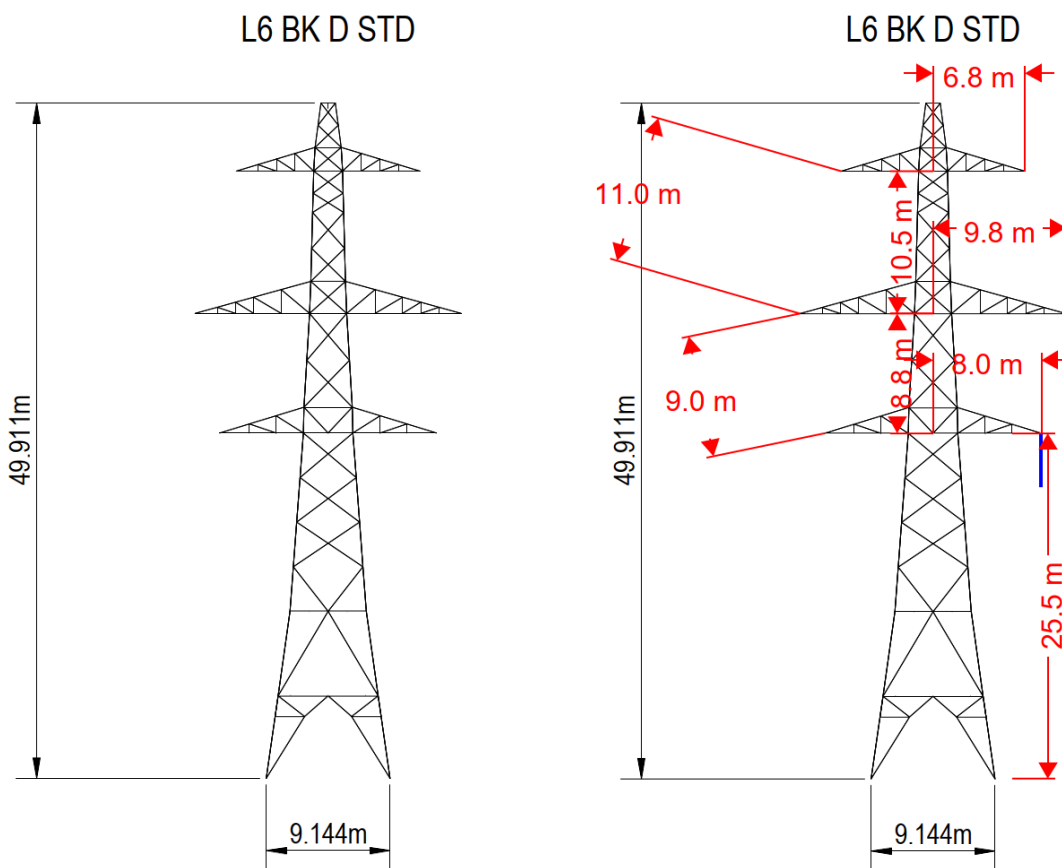

a)

b)

Figure 1 – OHL configuration

3.1.3 Figure 2 illustrates the approximate locations of 4ZM OHL, Finaline and Fosse Green Energy Circuit, along with the Soil Resistivity traverse sampling locations overlaid. The Finaline is represented by the red line orientated north-west-north to south-west-south, the 4ZM OHL is represented by the dark blue line, and the Fosse Green Energy circuit is represented by the turquoise line.

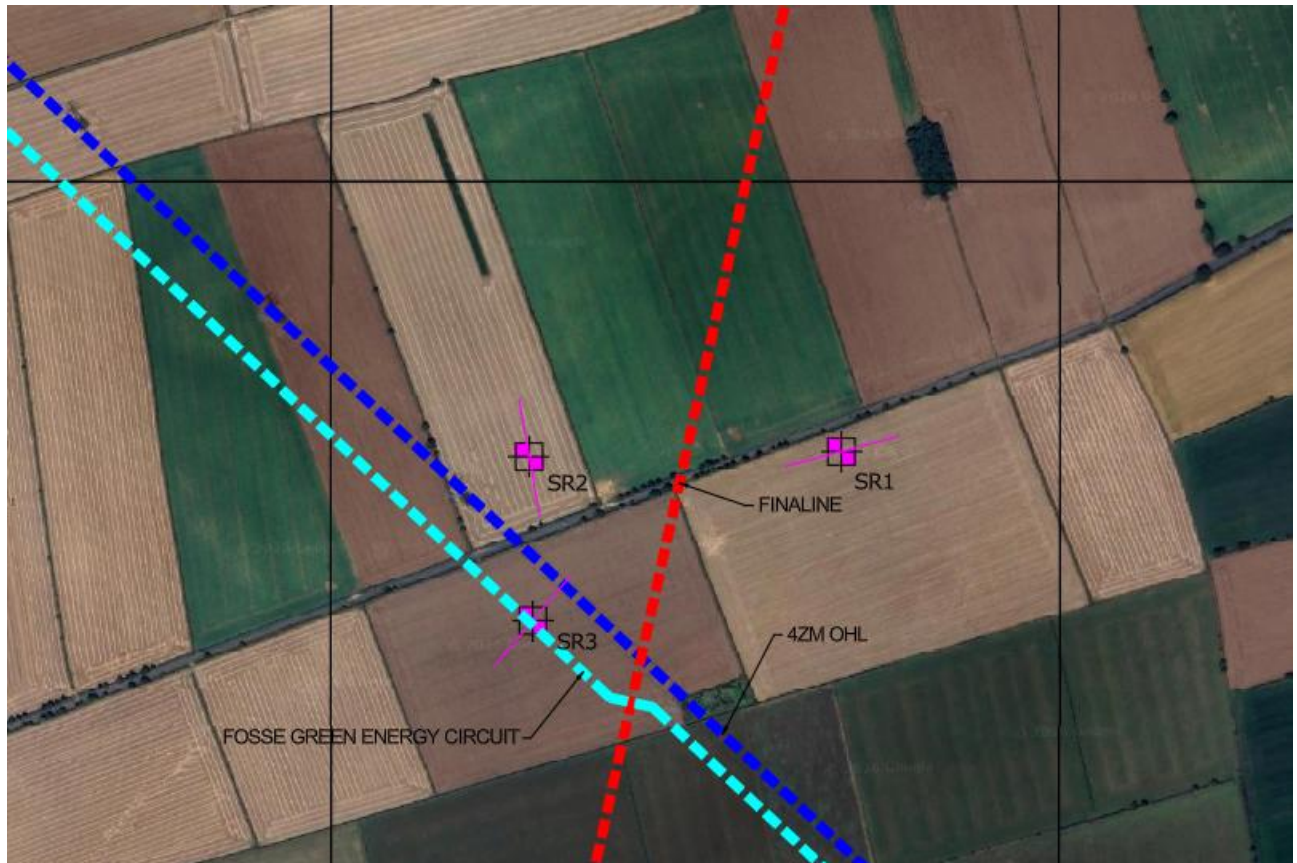

Figure 2 – Approximate locations of 4ZM OHL, Finaline and Fosse Green Energy Circuit, Soil Resistivity traverse locations overlaid

OHL Conductor Characteristics

- 3.1.4 The type of existing OHL conductors were obtained from NGET documentation; the existing phase conductors are of type 700mm² AAC – Araucaria; the existing overhead ground wire is of type 160mm² Optical Ground Wire.
- 3.1.5 Conductor types, similar to those stated in NGET documentation, were then imported from the SESLibrary (Ref 3). SESLibrary database IDs for the conductor types are presented in Table 3.
- 3.1.6 Values for Load Resistance, Load Inductance, Load Capacitance and Working (Corrosion) Potential have been left as default.

Table 3 – Characteristics of conductors used to model 4ZM OHL

Conductor Type	Relative Resistivity	Relative Permeability	Outer Radius R_{out} (m)	Internal Radius R_{in} (m)	Load Resistance R_i (Ohms), Working Potential V (Volts), Load Inductance L_i (Henries), and Load Capacitance C_i (μF)	Capacitance (MOhms*K m)	Identification	Database ID
Earth Wire	2.45872	1	0.00975	0.004185	0	N/A	OPGW	[AACSR/GS] AACSR - GS_Kezhak
Phase	2.55882	1.03405	0.01863	0	0	N/A	Phase	[Silmalec] Araucaria

Source (Ref 3)

Tower Characteristics

3.1.7 Tower earthing arrangements have been assumed in accordance with NGET earthing models.

Substation Impedances

3.1.8 West Burton substation and Bicker Fen substation were modelled as block impedances at the extents of the OHL.

3.1.9 West Burton substation impedance has been modelled at 0.1 Ω in accordance with NGET earthing system impedance measurements.

3.1.10 Bicker Fen substation impedance has been assumed to be 0.1 Ω .

Conductor Loading

3.1.11 In accordance with the National Energy System Operator (NESO) Electricity Ten Year Statement (ETYS) Appendix B, the loading of the West Burton to Bicker Fen OHL is assumed to be 3326 MVA (Winter Rating) per circuit (Ref 4). There are 2 circuits on the OHL (BICF41 – WBUR41) and BIC41 – WBUR42).

3.2 Finaline Pipeline

3.2.1 Finaline was modelled as described in Table 4 and Table 5. The pipeline was modelled at a depth of 4 feet (1.2192m) in accordance with (Ref 1).

Pipeline Coating Characteristics

3.2.2 Table 4 presents the pipeline coating characteristics.

- 3.2.3 Pipeline coating resistance is specified in type Area Resistance as opposed to Resistivity, Length Resistance and Resistance because Area Resistance is provided by BPA (Ref 1).
- 3.2.4 Relative Permittivity and Relative Permeability have been left as default.
- 3.2.5 In the absence of thickness being provided by BPA (Ref 1) a value of 0.0005 m has been assumed.

Table 4 – Pipeline coating characteristics

Coating Definition	Material Specification				Leakage Impedance Specification				
					Resistance Specification		Reactance Specification		
Resistive Part	Reactive Part	Resistivity (Ωm)	Relative Permittivity (p.u.)	Relative Permeability (p.u.)	Coating Resistance (Ωm ²)	Reference Frequency (Hz)	Coating Reactance	Reference Frequency (Hz)	Thickness (m)
Area Resistance	Permittivity	N/A	1	1	30000	0	N/A	N/A	0.0005 ¹

Source: (Ref 1)

Pipeline Conductor Characteristics

- 3.2.6 Table 5 presents the pipeline conductor characteristics. Physical pipeline conductor characteristics modelled were in accordance with the physical characteristics provided by BPA (Ref 1).
- 3.2.7 BPA indicate the pipeline is steel to grade API 5L X52 ERW. Relative resistivity values presented are understood to be indicative of steel are relative to that of Copper.
- 3.2.8 All pipeline conductor characteristics used in modelling are presented in this report.

Table 5 – Pipeline conductor characteristics

Conductor Type	Relative Resistivity	Relative Permeability	Outer Radius R _{out} (m)	Internal Radius R _{in} (m)	Load Resistance Ri (Ohms), Working Potential V (Volts), Load Inductance Li (Henries), Load Capacitance Ci (µF)	Capacitance (MOhms*K (m))	ID type	Database ID
User-Defined	10	300	0.136525	0.130125	0	N/A	Pipeline	N/A

Source: (Ref 3)

¹ Thickness unknown as stated in [Ref 1] Typical value of 500 µm (0.0005 m) assumed.

3.2.9 Cathodic Protection (CP) of type Impressed Current is provided on Finaline. No a.c. mitigation measures are understood to be present on Finaline.

3.3 Fosse Green Energy Circuit

3.3.1 The Fosse Green Energy circuit was modelled as described in Table 6. It is assumed that the 400 kV circuit will be offset from the outermost conductor of the OHL by 30 m. This has been assumed based on the requirement set out in NGET Technical Guidance Note 287 to contact NGET when conducting works within 30 m.

Cable Characteristics

3.3.2 The 400 kV cables were modelled as Concentric cables in HIFREQ. In addition, they were modelled in trefoil formation. Phase-phase spacings of 0.26 m were adopted.

3.3.3 Cables parameters have been imported from SESLibrary. The equivalent conductor CSA for the modelled cable is Aluminium 1200 mm². The database ID for the cable modelled is 1P-ID665-400kV (Ref 3).

3.3.4 All cable characteristics used in modelling are presented in this report.

Table 6 – 400 kV cable characteristics

Component Name	Conductor Properties				Insulation Properties			
	Inner Radius (m)	Outer Radius (m)	Relative Resistivity	Relative Permeability	Outer Radius (m)	Resistivity (Ωm)	Relative Permittivity	Relative Permeability
Core	0	0.019544	1.273	1	0.052044	1E+12	2.3	1
Sheath	0.052044	0.054944	2.09819	1	0.060944	1E+10	7	1

Source: (Ref 3)

Crossing Cross Section

3.3.5 Section B-B provides an indicative appearance of the crossing (Ref 5), illustrated on Figure 3. The distance between the base of Finaline and the top of the 400 kV circuit has been modelled as 600 mm. The crossing angle between the cable route and Finaline has been modelled as 90 °. The 400 kV cables have been modelled as being installed in a trefoil arrangement, as illustrated below.

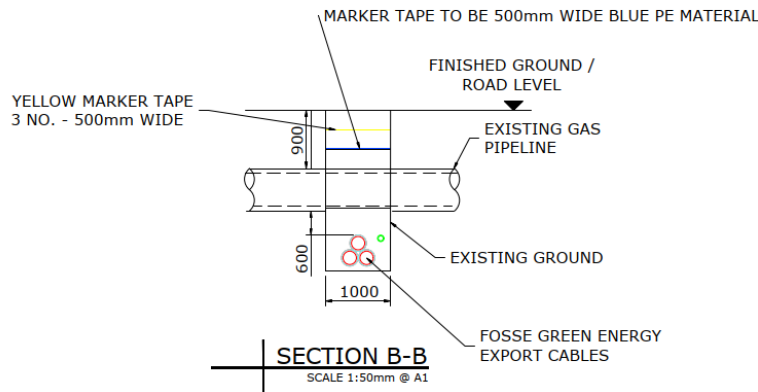
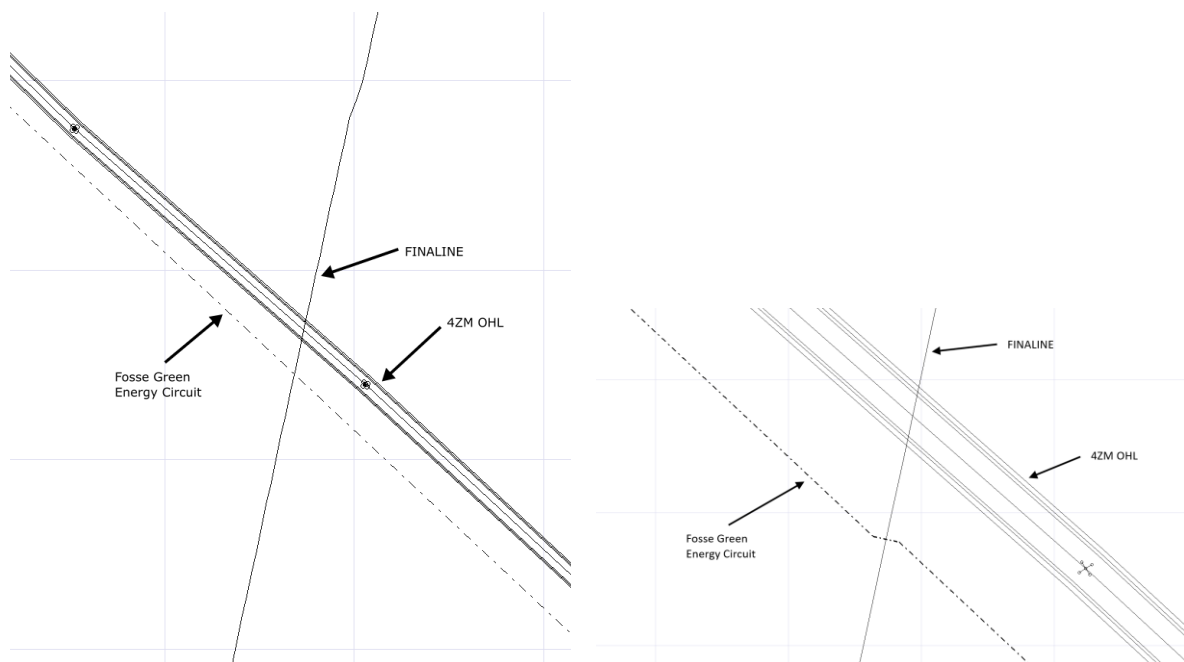

Figure 3 – Section B-B used as the basis for a.c. interference modelling (600 mm spacing between Finaline and 400 kV circuit)

3.4 HIFREQ Model

3.4.1 The HIFREQ model developed for the study is presented in Figure 4.



a) Overall view

b) Enhanced view to see crossing (90 ° crossing angle for 5 m either side of crossing point)

Figure 4 – HIFREQ models developed (dashed lines represent the 400kV cables, solid line (SW – NE) represents Finaline, solid lines (NW – SE) represent the OHL)

3.5 Modelled Scenarios

3.5.1 Two scenarios were considered for this study:

- Normal operation scenario (loading of 240 MW or 347 A per phase). This represents the 400 kV circuit at full load. In addition, the loading of the 4ZM OHL is taken into account (loading of 3326 MVA or 4800 A per phase at unity power factor). The normal operation scenario is presented in three parts:
 - Contributions of 4ZM OHL
 - Contributions of Fosse Green Energy circuit
 - Combined contributions of 4ZM OHL and Fosse Green Energy circuit
 - A single phase – ground fault of 11.56 kA has been considered. Characteristics of this fault scenario are:
 - 9.634 kA is the contribution from the future Navenby – West Burton 1 circuit for a fault at Navenby 400 kV. This has been taken from the NGET Substation Design Specification for Navenby 400 kV.
 - The operational scenario is that the future Navenby – West Burton 2 circuit is out of service.
 - The loading scenario on the future Navenby – West Burton 1 circuit is Summer Minimum level. Therefore, a safety factor of 20 % is added to account for the use of a Summer Minimum fault as opposed to a Winter Maximum fault level. This results in a fault value of 11.56 kA. It is noted that the difference between the Summer Minimum and the Winter Maximum loading on the 4ZM OHL is 12 % (Ref 4). A 20 % uptick is therefore considered conservative.
 - The fault is injected into the earthing system of the nearest tower to the Finaline – OHL crossing (tower designation 4ZM525).
- 3.5.2 It is noted that the existing OHL is designated as West Burton – Bicker Fen. Prospective fault values for the Navenby – West Burton 1 circuit is provided as to increase accuracy of the modelling. The inclusion of Navenby BESS cable is to be included in a future update.
- 3.5.3 It is noted that a Transfer Potential scenario associated with a GPR at a nearby joint bay of the Fosse Green energy circuit to Finaline has not been considered as it is understood that the more onerous scenario is that of a fault associated with the 4ZM OHL.
- 3.5.4 The modelling will be repeated at detailed design to verify that the effects are no greater than shown in this report.
- 3.5.5 Further scenarios associated with the 4ZM OHL, e.g. the OHL in unbalanced operation, are not considered as part of this assessment. It is noted that it is the responsibility of NGET to evaluate the effects, on Finaline, of proposed changes to their infrastructure.

3.6 Soil Resistivity

3.6.1 A conservative soil model was used for both scenarios: for a normal operations scenario, where Current Density is of concern, a lower resistivity soil model is considered conservative; for a fault scenario, where Touch Voltage is of concern, a higher soil resistivity is considered conservative.

Normal Operation Scenario

3.6.2 A single layer soil model was adopted, based on an unrealistic worst case soil resistivity. It is noted that soil model was solely used for modelling of Normal Operation Scenarios and does not reflect measured soil resistivity at the site. Real life soil monitoring showed the soil resistivity is much higher than this (in the order of 70 ohm-metre), which would reduce the impact of a.c. interference from the Proposed Development on the pipeline. This means that the corrosion risk is modelled as 'very high' and is therefore likely to overestimate the impact of the existing OHL and Proposed Development on the Finaline pipeline.

Table 1 – Assumed soil resistivity data (Normal Operation Scenario)

Layer	Resistivity (Ωm)
Air	∞
Soil	25.0

Fault Scenario

3.6.3 Soil resistivity measurements are presented in Appendix A and have been used for the assessment during a fault scenario. A single layer soil model was adopted using the lowest resistivity top soil layer calculated. The top soil layer from the traverse SR1 testing location was used, as shown in Figure 22. This is considered a conservative assumption as higher soil resistivity values will increase the Voltage seen on the Finaline pipeline. It is noted that soil model was solely used for modelling of Fault Scenario Scenarios – where the limitation is the maximum permissible Touch Voltage on Finaline.

Table 2 – Assumed soil resistivity data (Fault Scenario)

Layer	Resistivity (Ωm)
Air	∞
Soil	70.3

4. Results

4.1 Normal Operation Scenario

- 4.1.1 The current loading on the Fosse Green Energy circuit is based on a maximum 240 MW (347A) as a 'worst case' normal operating scenario. 'Worst case' signifies that this is a maximum loading scenario.
- 4.1.2 The current loading on the 400 kV OHL is based on a maximum 3326 MVA (4800 A at unity power factor) as a 'worst case' normal operating scenario. 'Worst case' signifies that this is a maximum loading scenario.
- 4.1.3 It is noted that a maximum loading scenario is not anticipated to be prolonged in duration and likely to be an infrequent occurrence.

Baseline Scenario - 4ZM OHL

- 4.1.4 This section presents the modelled baseline conditions, based on the impacts arising currently from the 4ZM OHL.

Pipeline Coating Ground Potential Rise (GPR)

- 4.1.5 Figure 5 shows a plot for GPR of pipeline coating. It can be seen that the maximum GPR calculated is 0.134 V (3 s.f.).

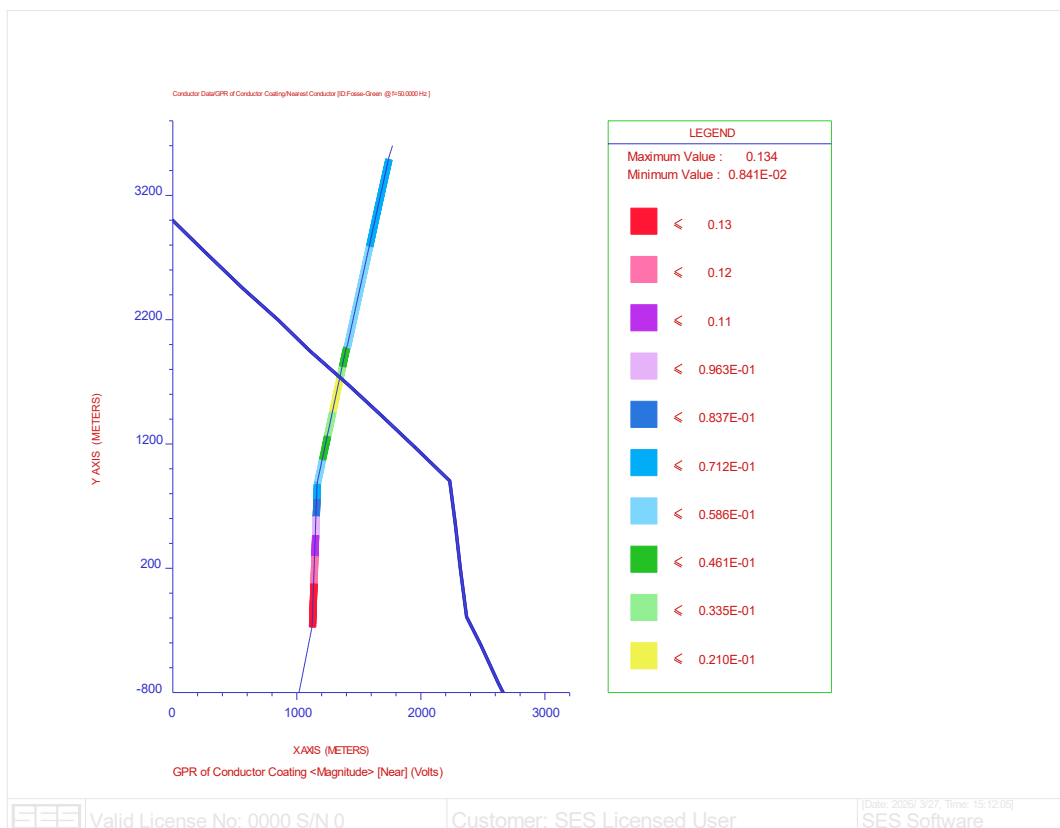

Figure 5 – Plot of GPR on pipeline coating (4ZM OHL, Normal Operation)

Pipeline GPR

4.1.6 Figure 6 shows a plot for GPR of pipeline conductor. It can be seen that the maximum GPR calculated is 8.34 V (3 s.f.). This is below the 15 V limit in Table 1.

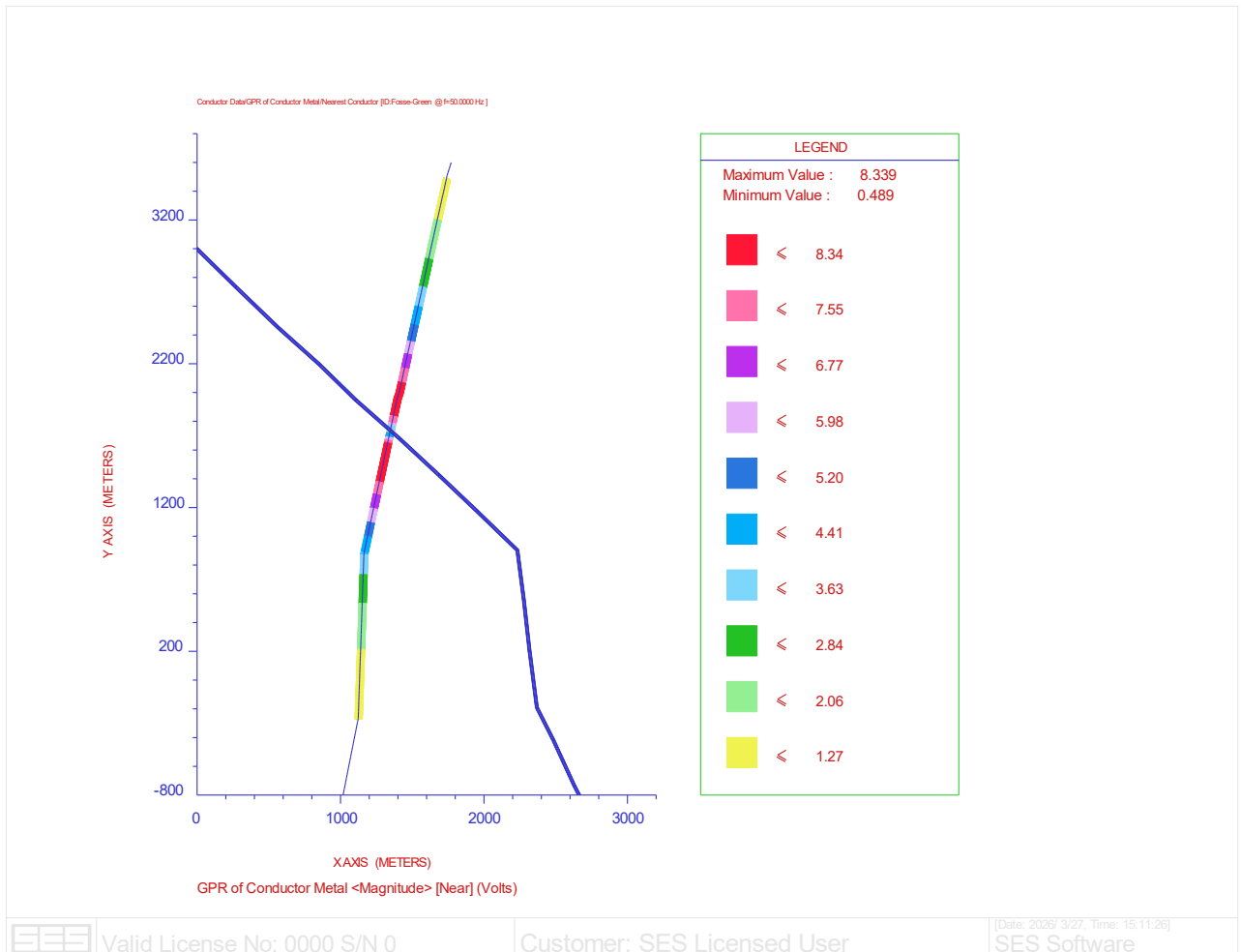

Figure 6 – Plot of GPR of the pipeline conductor (4ZM OHL, Normal Operation)

Current Density

- 4.1.7 The maximum GPR on the Finaline conductor is calculated to be 8.34 V. Equation 1, reprinted below, has been used to calculate AC current density on a 1 cm² coating defect.

$$I = \frac{8V}{\rho\pi d}$$

Table 7 – Current density on Finaline (4ZM OHL, Normal Operation). (Positive chainage represents North of crossing, negative chainage represents South of crossing).

ID/Chainage	Pipeline GPR (V)	Current Density (Am ⁻²)
Highest	8.34	75.3
Crossing + 500 m	6.46	58.3
Crossing + 1000 m	3.06	27.6
Crossing - 500 m	6.49	58.6
Crossing - 1000 m	3.02	27.3

- 4.1.8 The maximum Current Density on Finaline is calculated as being above the 30 Am⁻² limit stated in Table 1.
- 4.1.9 It is noted however that the soil resistivity value used in these calculations (25 Ωm) does not reflect measured soil resistivity at the site, as shown in Appendix A, and therefore may be causing actual impacts to be overestimated.

Development Scenario - Fosse Green Energy Circuit

- 4.1.10 This section presents the modelled impact of the Fosse Green Energy circuit in isolation, without considering the existing OHL.

Pipeline Coating GPR

- 4.1.11 Figure 7 shows a plot for GPR of pipeline coating. The maximum GPR calculated is 0.00000842V (3 s.f.).

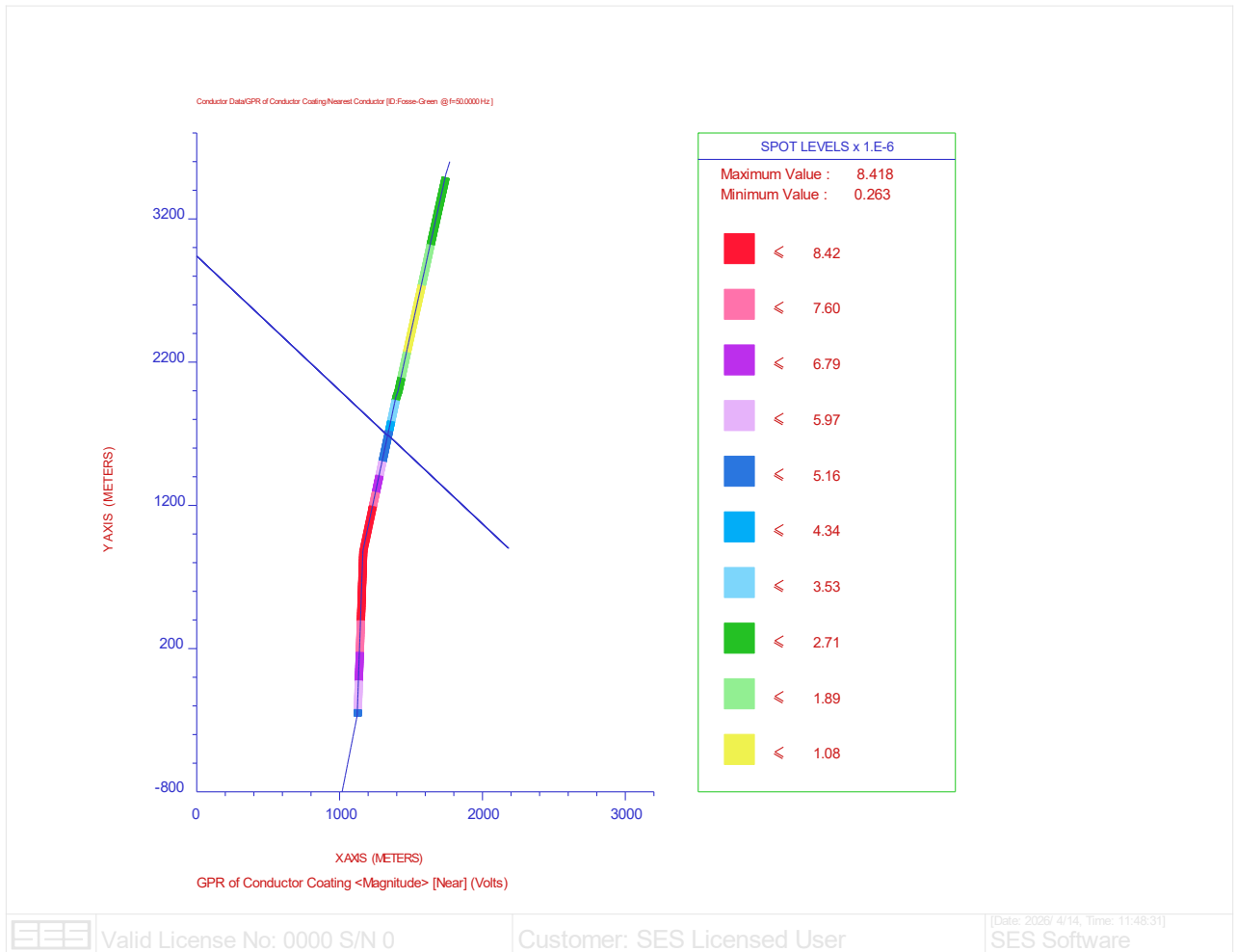

Figure 7 – Plot of GPR on pipeline coating (Fosse Green Energy circuit, Normal Operation)

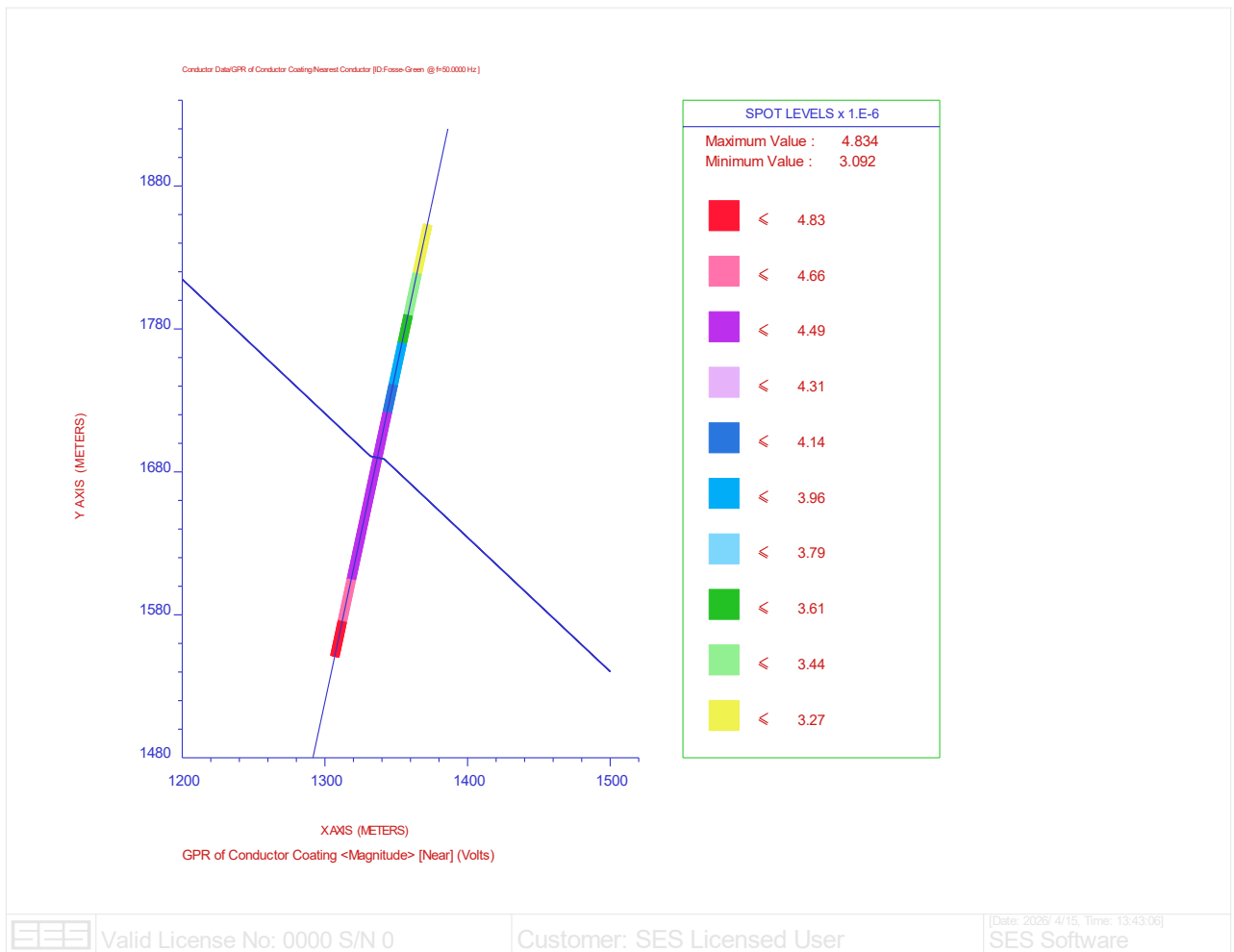

Figure 8 – Enhanced plot of GPR on pipeline coating (Fosse Green Energy circuit, Normal Operation)

Pipeline GPR

4.1.12 Figure 9 shows a plot for GPR of pipeline conductor. The maximum GPR calculated is 0.00283 V (3 s.f.). This is substantially below the 15 V limit in Table 1.

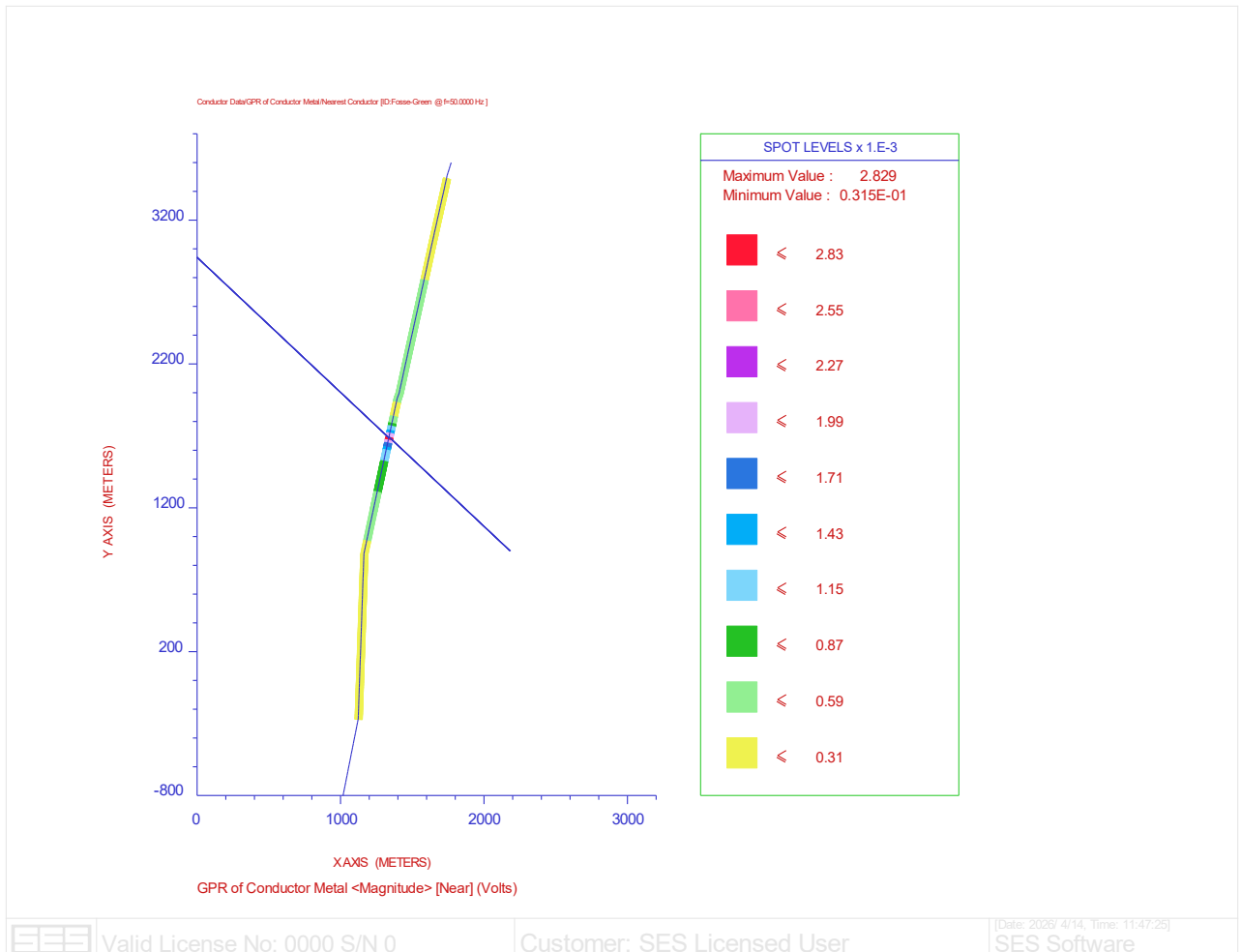

Figure 9 – Plot of GPR of the pipeline conductor (Fosse Green Energy circuit, Normal Operation)

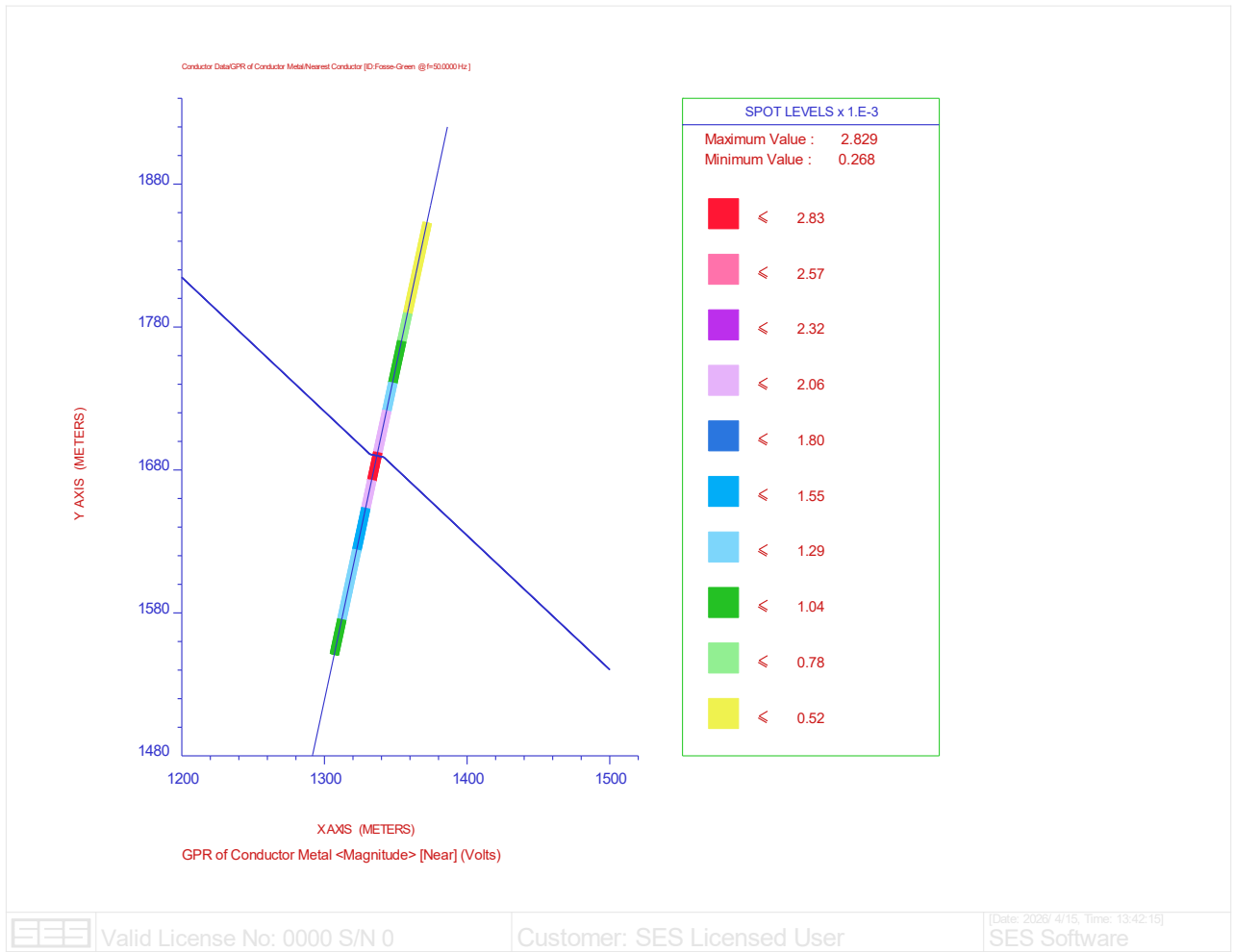

Figure 10 – Enhanced plot of GPR of the pipeline conductor (Fosse Green Energy circuit, Normal Operation).

Current Density

4.1.13 The maximum GPR on the pipeline conductor is calculated to be 0.00283 V. This is substantially below the 645 V limit in Table 1. Equation 1 has been used to calculate AC current density on a 1 cm² coating defect.

$$I = \frac{8V}{\rho\pi d}$$

Table 8 – Current density on Finaline (Fosse Green Energy circuit, Normal Operation). (Positive chainage represents North of crossing, negative chainage represents South of crossing).

ID/Chainage	Pipeline GPR (V)	Current Density (Am ⁻²)
Highest	0.00283	0.0256
Crossing + 500 m	0.0004732	0.0043
Crossing + 1000 m	0.0003386	0.0031
Crossing - 500 m	0.0004531	0.0041
Crossing - 1000 m	0.0002503	0.0023

4.1.14 The calculated Current Density is presented to reiterate the small contribution to Current Density on Finaline from the Fosse Green Energy circuit – see Normal Operation Scenario 3 for the calculated cumulative effects of the OHL and the Fosse Green Energy circuit. The worst case current density is 0.0256 Am⁻² which represents 0.085 % of the limit in Table 1.

Combined Modelled Effects - 4ZM OHL and Fosse Green Energy Circuit

4.1.15 This section presents the modelled baseline conditions arising from the 4ZM OHL along with the Fosse Green Energy circuit. It presents the modelled impact predicted to arise, therefore.

Pipeline Coating GPR

4.1.16 Figure 11 shows a plot for GPR of pipeline coating. The maximum GPR calculated is 0.137 V (3 s.f.).

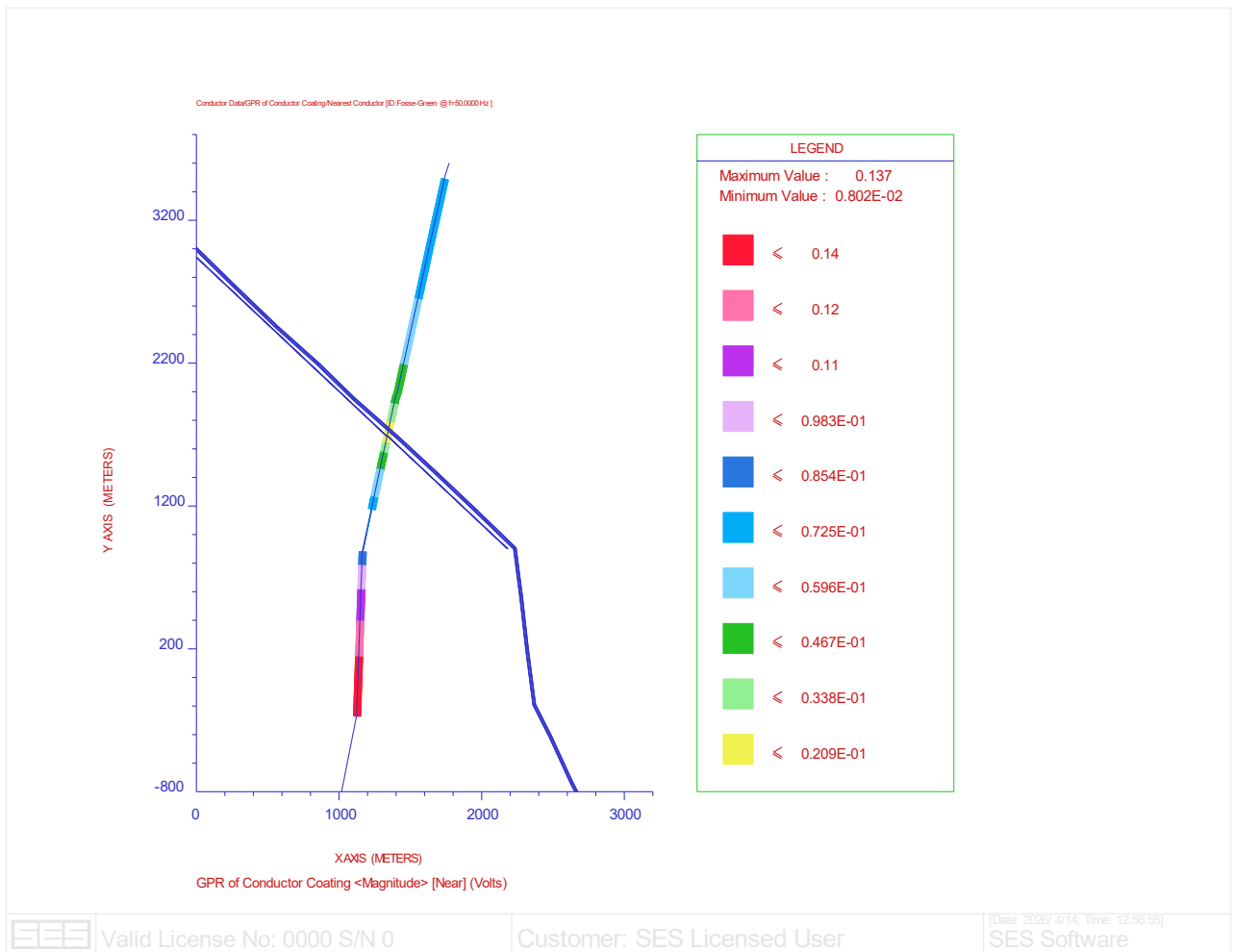

Figure 11 – Plot of GPR on pipeline coating (4ZM OHL and Fosse Green Energy circuit, Normal Operation)

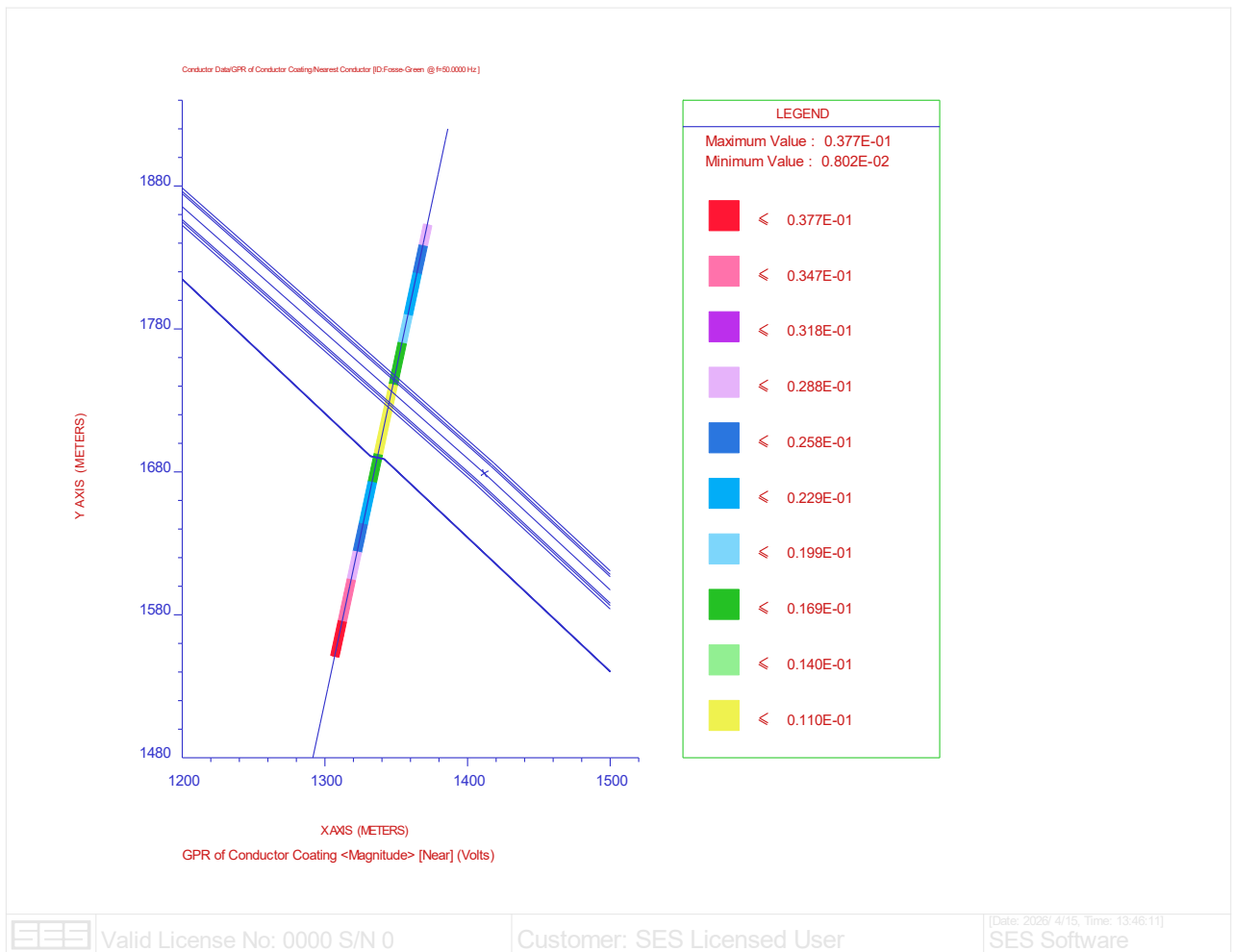

Figure 12 – Enhanced plot of GPR on pipeline coating (4ZM OHL and Fosse Green Energy circuit, Normal Operation)

Pipeline GPR

4.1.17 Figure 13 shows a plot for GPR of the pipeline conductor. The maximum GPR calculated is 8.32 V (3 s.f.). This is substantially below the 15 V limit in Table 1.

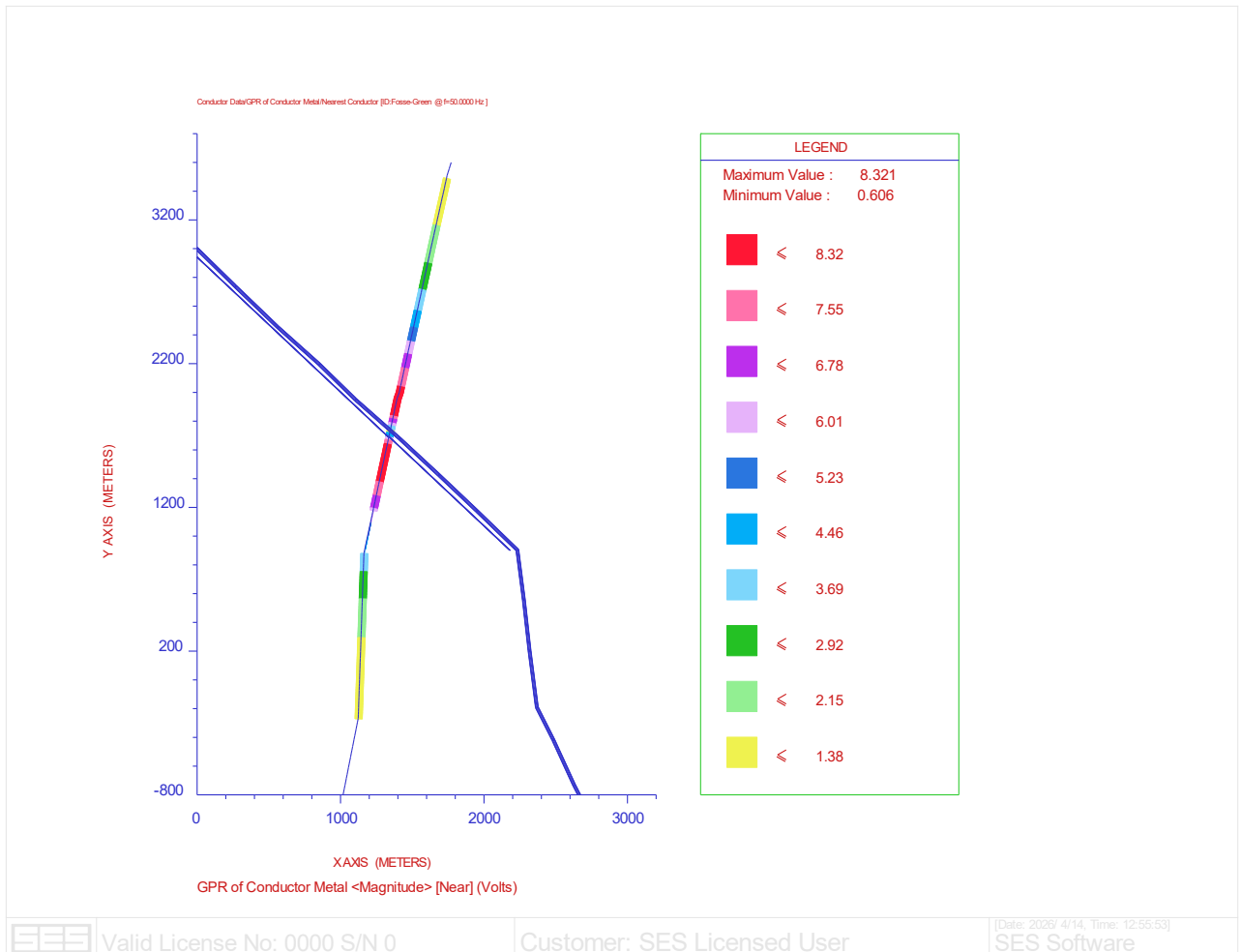

Figure 13 – Plot of GPR of the pipeline conductor (4ZM OHL and Fosse Green Energy circuit, Normal Operation)

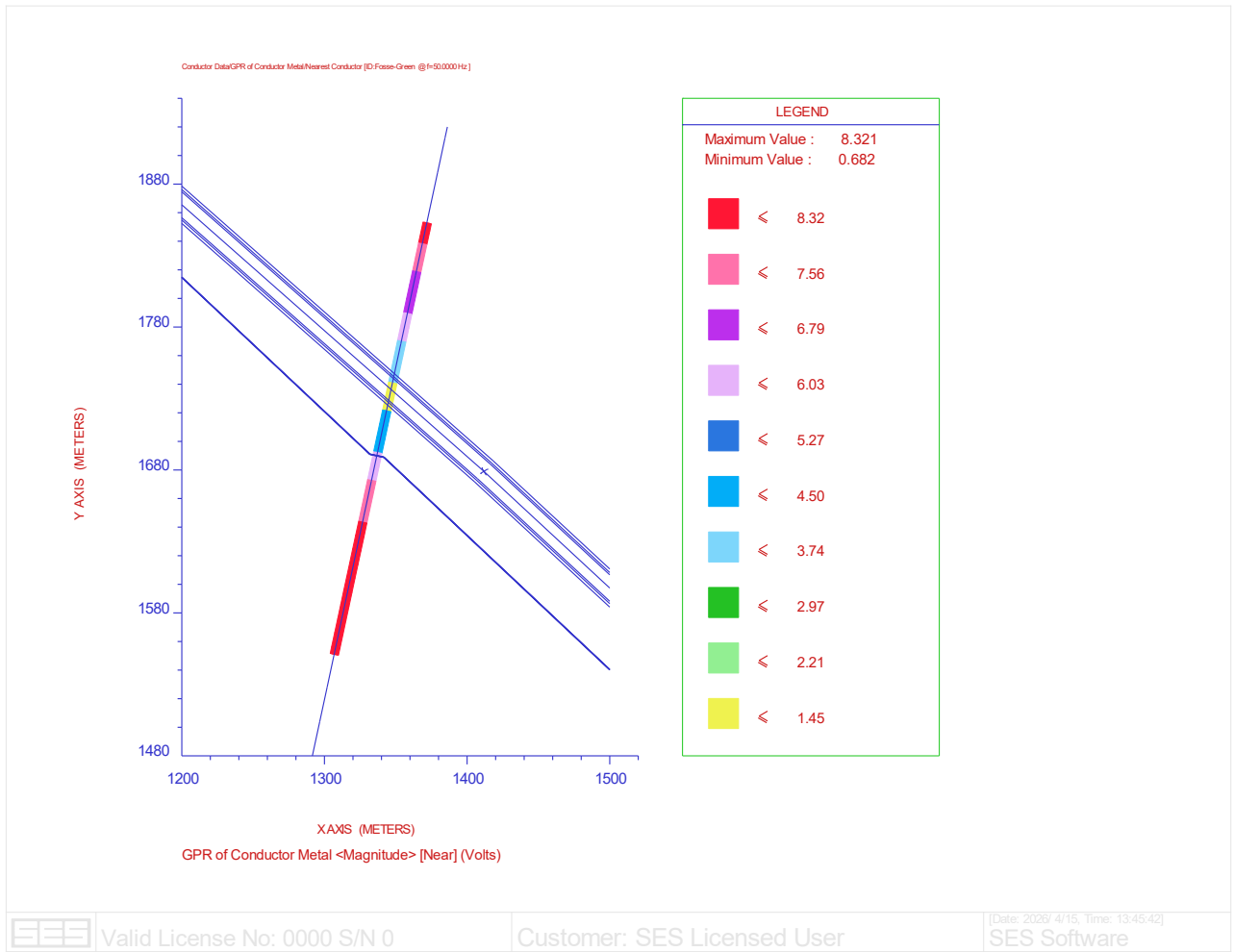

Figure 14 – Enhanced plot of GPR of the pipeline conductor (4ZM OHL and Fosse Green Energy circuit, Normal Operation)

Current Density

4.1.18 The maximum GPR on the pipeline conductor is calculated to be 8.32 V. Equation 1 has been used to calculate AC current density on a 1 cm² coating defect.

$$I = \frac{8V}{\rho\pi d}$$

Table 9 – Current density on Finaline (4ZM OHL and Fosse Green Energy circuit, Normal Operation). (Positive chainage represents North of crossing, negative chainage represents South of crossing).

ID/Chainage	Pipeline GPR (V)	Current Density (Am ⁻²)
Highest	8.32	75.1
Crossing + 500 m	6.42	58.0
Crossing + 1000 m	3.04	27.5
Crossing - 500 m	6.47	58.4
Crossing - 1000 m	2.99	27.0

4.1.19 The maximum GPR is m as above the 30 Am⁻² limit stated in Table 1. A comparison of the Current Density calculated for the Normal Operation Scenario 1 - 4ZM OHL and the Normal Operation Scenario 3 – 4ZM OHL and Fosse Green Energy circuit shows that the Fosse Green Energy circuit when situated 30 m South of 4ZM OHL is expected to decrease the maximum Current Density on Finaline by 0.265 % (3 s.f.). This is due to the electro-magnetic fields interfering with one another.

$$\frac{75.3 - 75.1}{75.3} = 0.00265 \equiv \downarrow 0.265 \%$$

4.1.20 This calculation reiterates the negligible impact the Fosse Green Energy circuit is expected to have on the Current Density on Finaline.

4.1.21 It is noted that calculations suggest that the Current Density a.c. corrosion limit of 30 Am⁻² is exceeded on Finaline with just the OHL present (Normal Operation Scenario (1)).

4.1.22 Maximum Current Density is susceptible to the relative location of the Fosse Green Energy cable and the 4ZM OHL. It is understood that the spacing between the Fosse Green Energy circuit and the 4ZM OHL will affect the how their respective electro-magnetic fields interfere with each other.

4.2 Fault Scenario

- 4.2.1 To test a fault scenario, a 11.56 kA was injected into the earthing system of the nearest OHL to the Pipeline – OHL crossing (tower designation 4ZM525).
- 4.2.2 In the fault scenario the relevant limitation changes from that of an a.c. corrosion related limit to that of Touch Voltage safety limit. The Touch Voltage safety limit is shown in Table 1.
- 4.2.3 It is noted that fault conditions are rare (e.g., in the order of once every several years). The health and safety risk to individuals maintaining or repairing the pipeline is considered very low based on the short duration of the repairs and frequency of the fault.

4ZM OHL and Fosse Green Energy Circuit

Pipeline Coating GPR

- 4.2.4 Figure 15 shows a plot for GPR of pipeline coating. The maximum GPR calculated is 338 V. Pipeline Coating Stress Voltage is defined as the difference between the GPR of the coating and the metal GPR of each conductor segment – it can be seen from comparison of Figure 15 and Figure 17 that during a fault scenario the Pipeline Coating Stress Voltage limit of 3000 V is not exceeded.

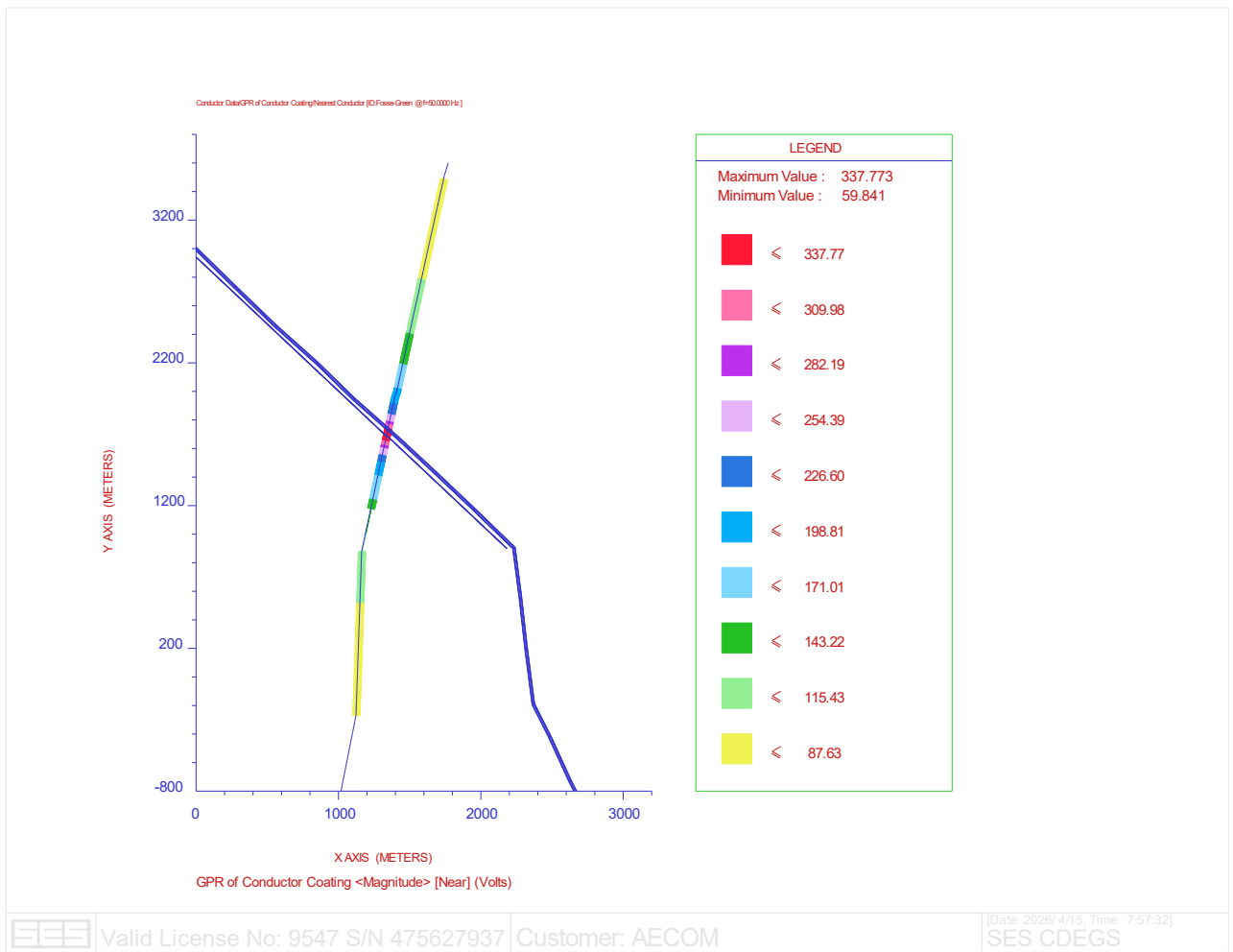

Figure 15 – Plot of GPR on pipeline coating (4ZM OHL and Fosse Green Energy circuit, Fault)

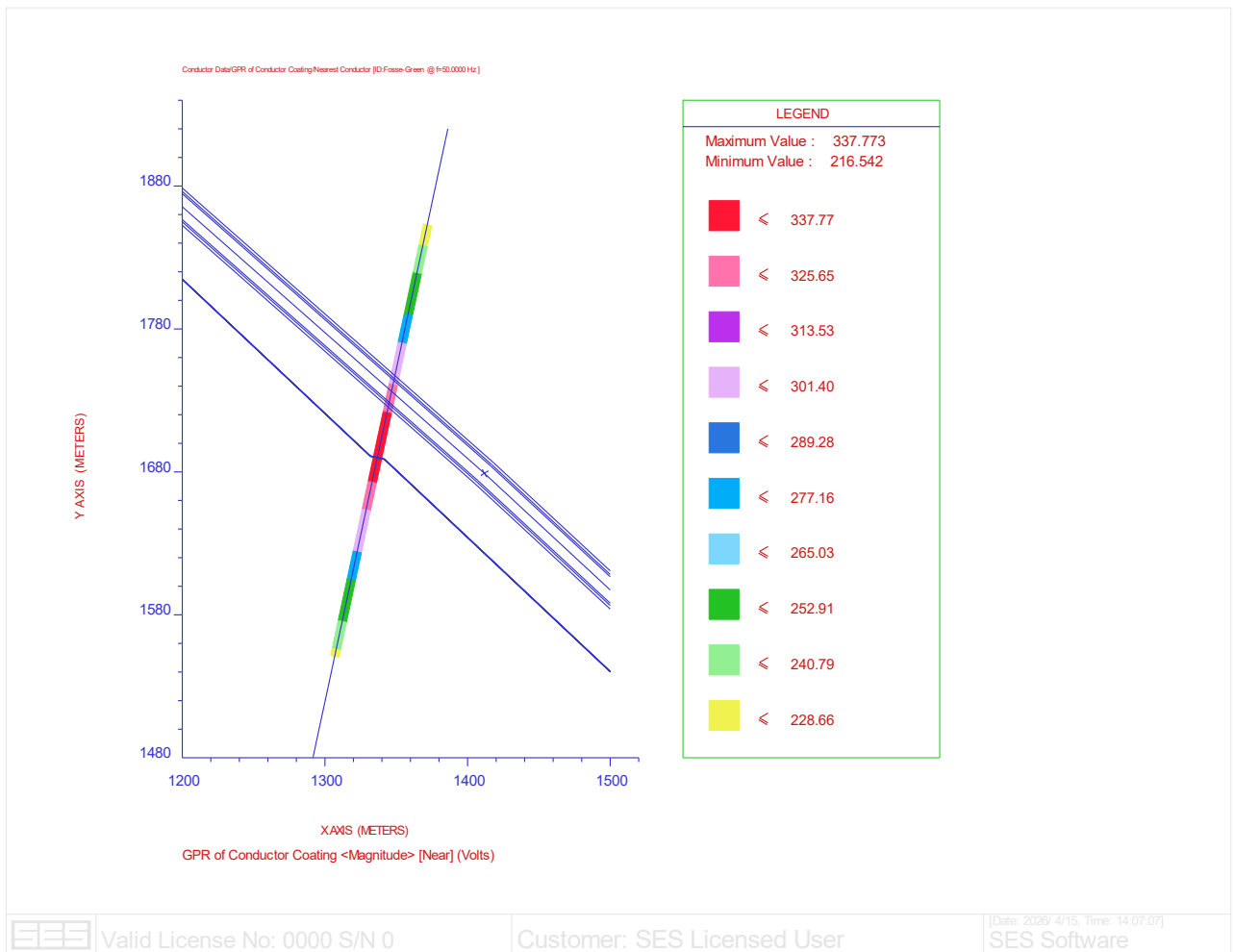

Figure 16 – Enhanced plot of GPR on pipeline coating (4ZM OHL and Fosse Green Energy circuit, Fault)

Pipeline GPR

4.2.5 Figure 17 shows a plot for GPR of the pipeline conductor. It can be seen that the maximum GPR calculated is 221 V. Therefore, during a fault scenario the Touch Voltage safety limit of 645 V is not exceeded.

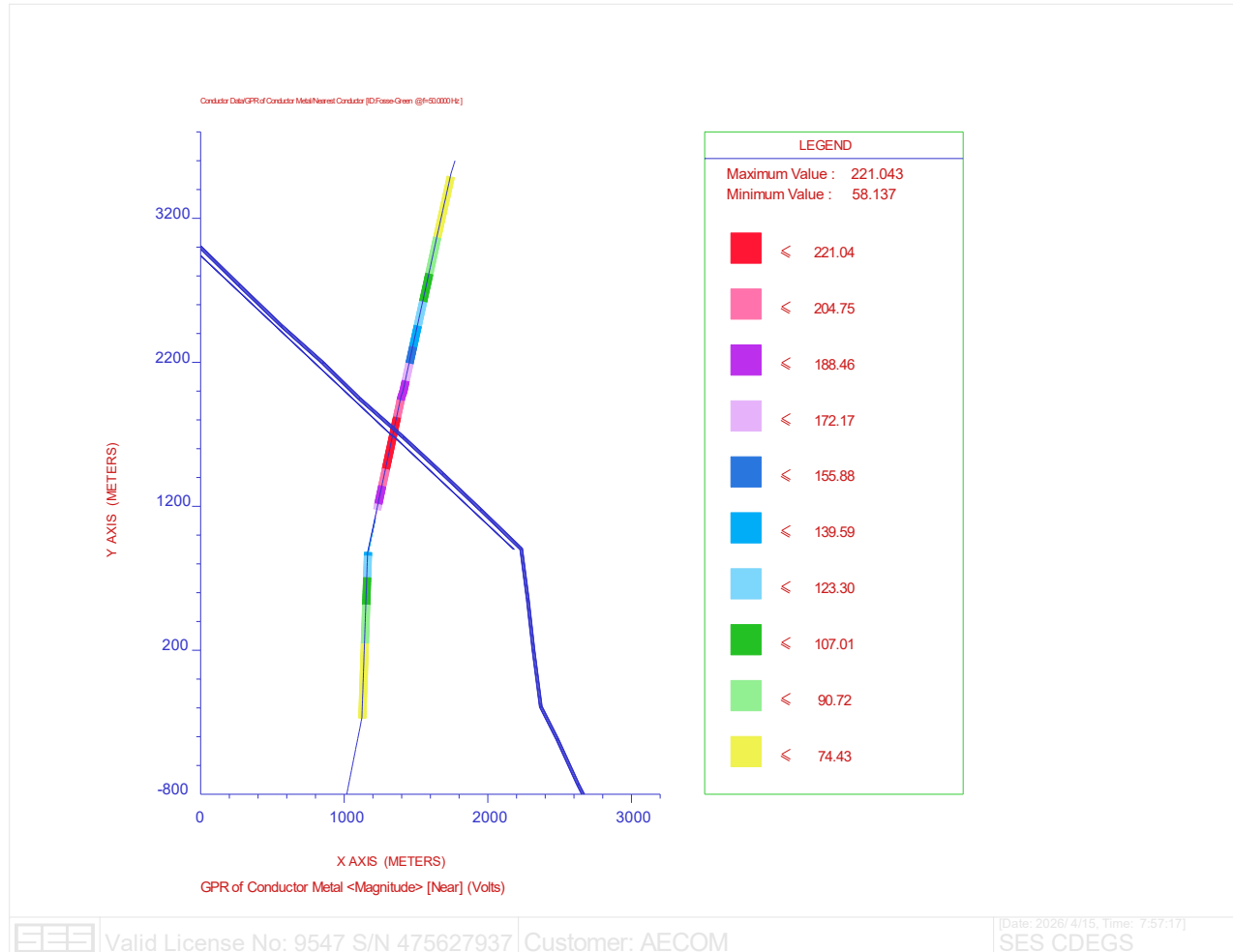

Figure 17 – Plot of GPR on pipeline conductor (4ZM OHL and Fosse Green Energy circuit, Fault)

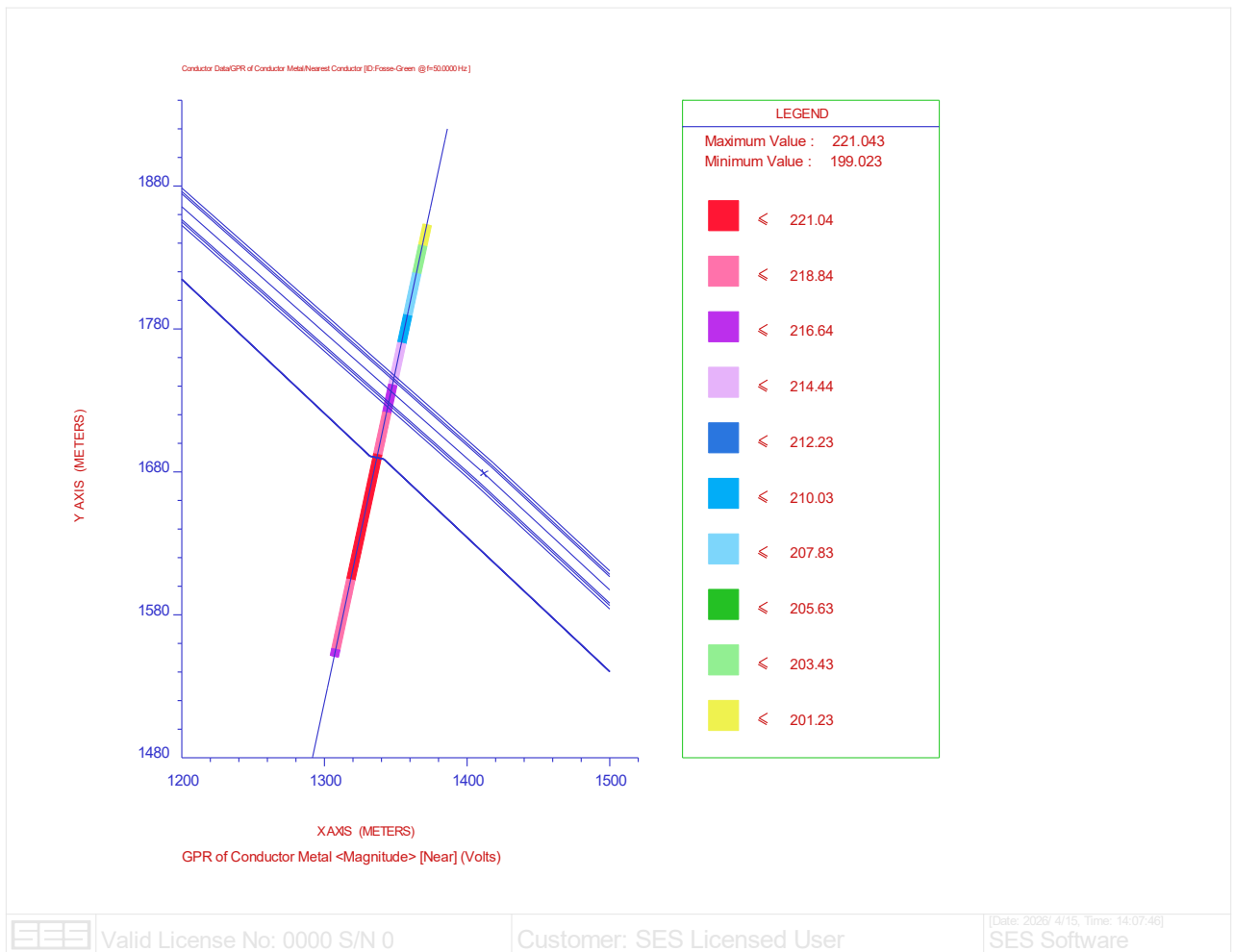

Figure 18 – Enhanced plot of GPR on pipeline conductor (4ZM OHL and Fosse Green Energy circuit, Fault)

5. Conclusion

5.1.1 This section presents the conclusion of the modelling results. The following results assume that no a.c. mitigation measures are installed – this is understood to be true for the North section of the pipeline in accordance with information provide by BPA (Ref 1).

5.2 Normal Operation Scenario

(1) 4ZM OHL

5.2.1 During the normal operation scenario, the Current Density calculated on Finaline is modelled to be above the 30 Am⁻² limit stated in the UKOPA/GPG/027 guidance document, in terms of a.c. corrosion. This is a maximum loading scenario, which is not anticipated to be prolonged in duration and likely to be an infrequent occurrence.

5.2.2 It is noted that Current Density exceedances are identified based on AECOMs assumption of OHL load and soil resistivity, which may be overestimating the existing impacts.

5.2.3 Touch Voltages on Finaline were found to be within the Touch Voltage safety limit of 15 V.

(2) Fosse Green Energy Circuit

5.2.4 During the normal operation scenario, the Current Density calculated on Finaline was below the 30 Am⁻² limit stated in the UKOPA/GPG/027 guidance document, in terms of a.c. corrosion. The calculated Current Density on Finaline as a result of, solely, the proposed Fosse Green Energy circuit is 0.0256 Am⁻² during a normal operating scenario, which is 0.085 % of the limit and therefore negligible.

5.2.5 Touch Voltages on Finaline were found to be within the Touch Voltage safety limit of 15 V.

(3) 4ZM OHL and Fosse Green Energy Circuit

5.2.6 During the normal operation scenario, the Current Density calculated on Finaline when combining the 4ZM OHL and Fosse Green Energy was above the 30 Am⁻² limit stated in the UKOPA/GPG/027 guidance document in terms of a.c. corrosion. This is due to the 4ZM OHL.

5.2.7 Based on the modelling parameters as outlined in this document, the maximum Current Density calculated on Finaline is expected to decrease (by a negligible amount) as a result of the proposed Fosse Green Energy circuit. This is due to the interaction of the electromagnetic fields. This is a considered to be a negligible beneficial effect.

5.2.8 It is noted that Touch Voltages on Finaline were found to be within the Touch Voltage safety limit of 15 V.

5.3 Fault Scenario

- 5.3.1 Fault conditions are rare (e.g., in the order of once every several years) but important to model. The health and safety risk to individuals maintaining or repairing the pipeline is usually considered very low based on the short duration of the repairs and frequency of the fault.
- 5.3.2 For the fault scenario, calculated Touch Voltages on Finaline were found to be within the Touch Voltage safety limit of 645 V.
- 5.3.3 Nevertheless, operatives on Finaline should still be made aware of the Fosse Green Energy cable circuit by Prax before carrying out maintenance or repair work, and the appropriate PPE footwear should be worn, i.e. footwear with a Resistance greater than that assumed in the Touch Voltage limit calculation in BS EN 50122.

6. References

- Ref 1 "UKOPA-GPG-027-AC-Corrosion-Oct-19-Ed-1-1 - App C + D FINA FOSSE Green.pdf".
- Ref 2 N. G. E. Transmission, "<https://www.nationalgrid.com/electricity-transmission/network-and-infrastructure/network-route-maps>".
- Ref 3 SES, "SESConductorDatabase".
- Ref 4 National Energy System Operator (NESO), "Electricity Ten Year Statement (ETYS) Appendix B," 2024.
- Ref 5 AECOM, "400KV CABLE TYPICAL UTILITY CROSSING DETAIL.pdf," 2025.
- Ref 6 National Grid Electricity Transmission, "THE GRID CODE," 2017.

Appendix A Soil Resistivity Data

Soil resistivity testing was performed by Roberts Environmental. Locations of tests can be seen in Figure 19.

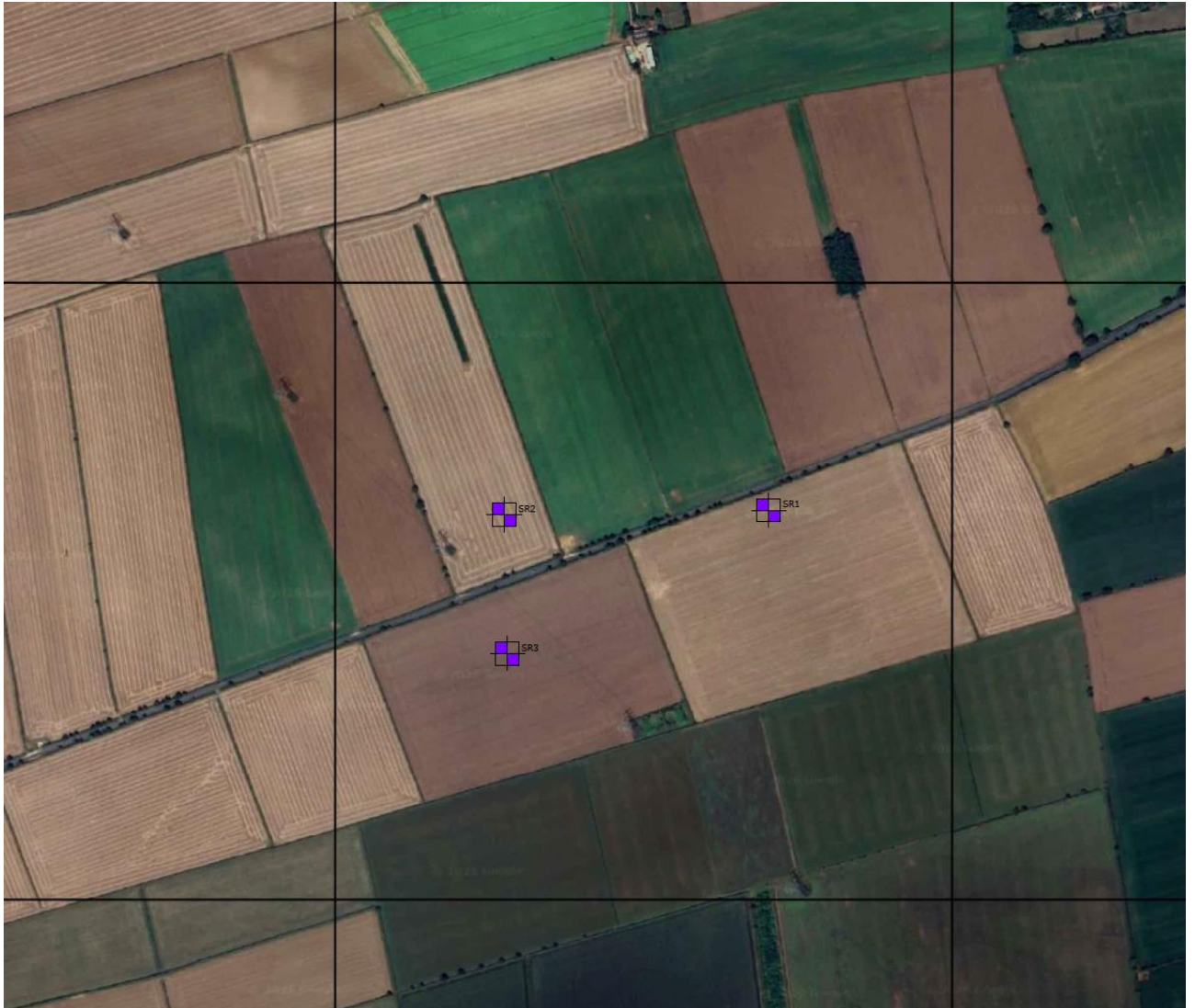

Figure 19 – Soil resistivity test locations

SR1

Tabulated measurements alongside the developed soil models for location SR1 can be seen below.

Table 10 – SR1 soil resistivity data

Orientation	Electrode (m)	Spacing	Nominal Test Depth (m)	R ₁	R ₂	R _{av}	Apparent Resistivity
075/255	0.5		0.5	44.7	44.7	44.7	140.43
075/255	1		1	23.8	23.8	23.8	149.54
075/255	1.5		1.5	14.0 6	14.0 7	14.0 7	132.56
075/255	2		2	10.5 6	10.5 7	10.5 7	132.76
075/255	3		3	7.57	7.57	7.57	142.69
075/255	4		4	6.07	6.07	6.07	152.56
075/255	4.5		4.5	5.55	5.55	5.55	156.92
075/255	6		6	4.63	4.62	4.63	174.36
075/255	9		9	3.58	3.58	3.58	202.44
075/255	13.5		13.5	2.65	2.65	2.65	224.78
075/255	18		18	2.03	2.04	2.04	230.15
075/255	27		27	1.19 6	1.19 8	1.19 7	203.07
075/255	36		36	0.71 9	0.72 0	0.72 0	162.75
075/255	54		54	0.28 0	0.28 0	0.28 0	95.00

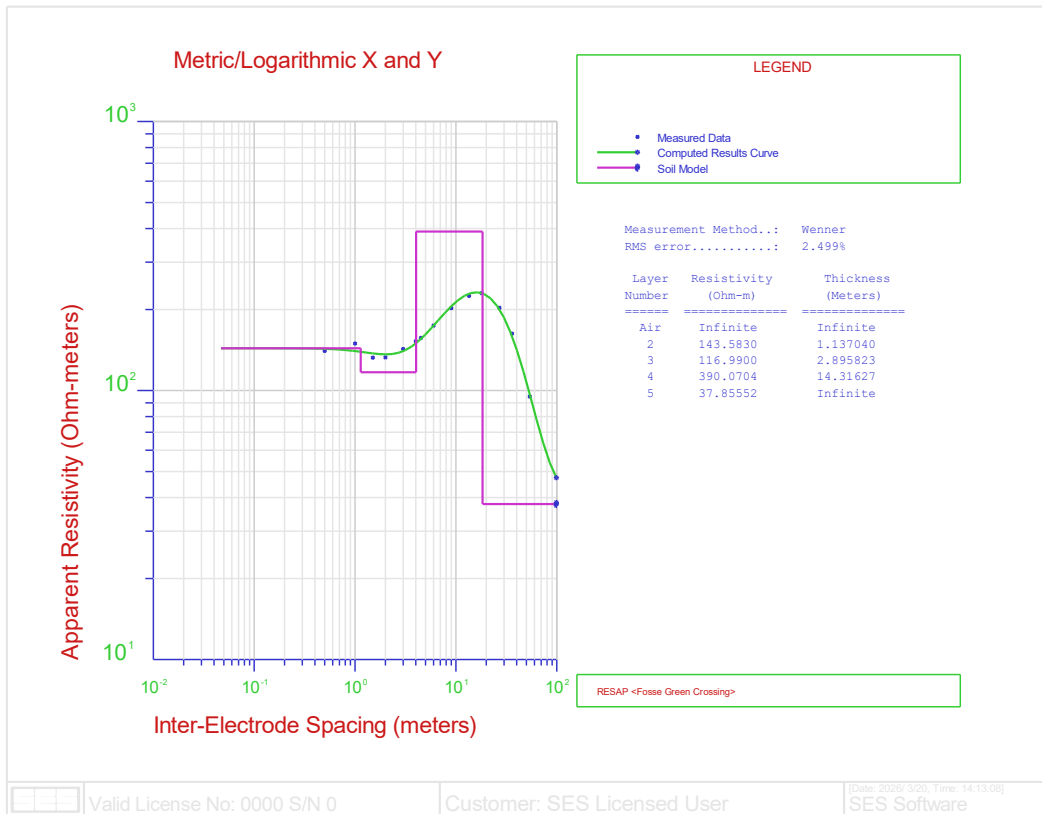

Figure 20 – SR1 developed soil model

SR2

Tabulated measurements alongside the developed soil models for location SR2 can be seen below.

Table 11 – SR2 soil resistivity data

Orientatio n	Electrode (m)	Spacing	Nominal Test (m)	Depth	R ₁	R ₂	R _{av}	Apparent Resistivity
000/180	0.5		0.5		87.9	87.9	87.9	276.15
000/180	1		1		62.4	62.4	62.4	392.07
000/180	1.5		1.5		46.0	46.0	46.0	433.54
000/180	2		2		35.9	35.9	35.9	451.13
000/180	3		3		23.2	23.3	23.3	438.25
000/180	4		4		16.1 6	16.1 7	16.1 7	406.27
000/180	4.5		4.5		14.2 4	14.2 1	14.2 3	402.20
000/180	6		6		9.92	9.94	9.93	374.35
000/180	9		9		5.70	5.71	5.71	322.61
000/180	13.5		13.5		3.25	3.25	3.25	275.68
000/180	18		18		2.28	2.27	2.28	257.30
000/180	27		27		1.22 4	1.22 5	1.22 5	207.73
000/180	36		36		0.75 0	0.75 1	0.75 1	169.76
000/180	54		54		0.31 9	0.32 1	0.32 0	108.57

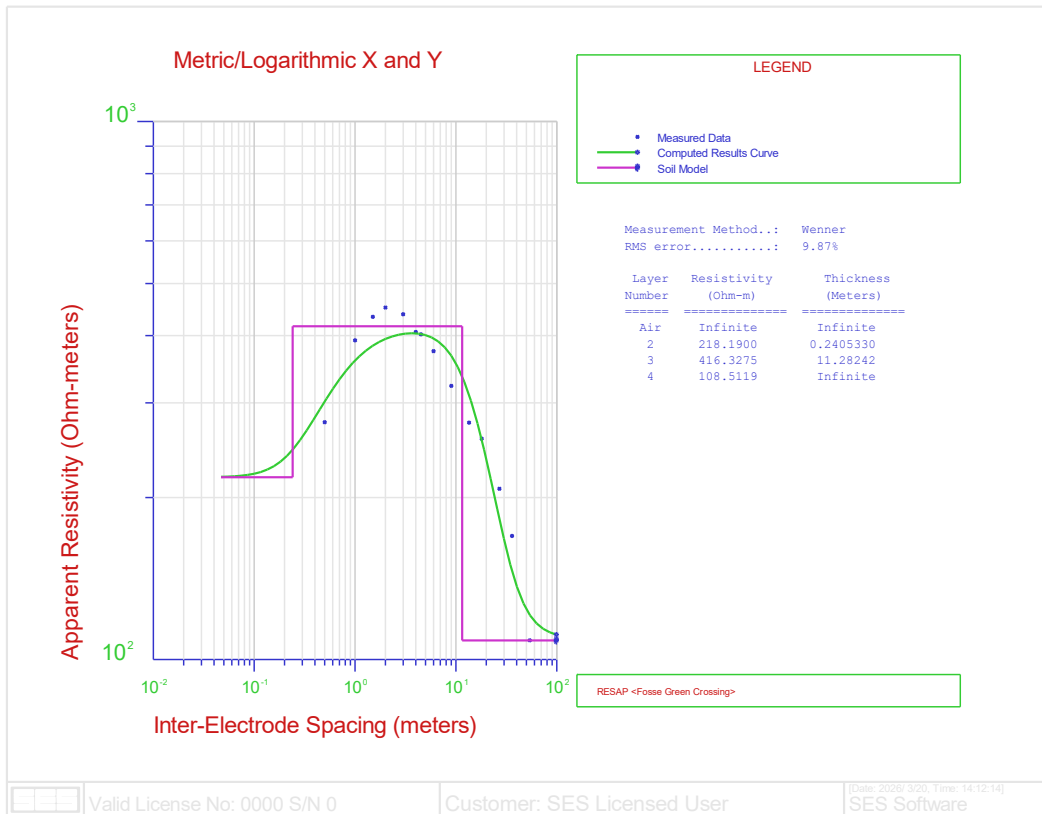

Figure 21 – SR2 developed soil model

SR3

Tabulated measurements alongside the developed soil models for location SR3 can be seen below.

Table 12 – SR3 soil resistivity data

Orientation	Electrode (m)	Spacing	Nominal Test Depth (m)	R ₁	R ₂	R _{av}	Apparent Resistivity
040/220	0.5		0.5	20.8	20.8	20.8	65.35
040/220	1		1	13.81	13.80	13.81	86.74
040/220	1.5		1.5	11.04	11.05	11.05	104.10
040/220	2		2	8.70	8.71	8.71	109.39
040/220	3		3	6.63	6.63	6.63	124.97
040/220	4		4	5.52	5.52	5.52	138.73
040/220	4.5		4.5	5.13	5.14	5.14	145.19
040/220	6		6	4.48	4.49	4.49	169.08
040/220	9		9	3.40	3.40	3.40	192.27
040/220	13.5		13.5	2.22	2.22	2.22	188.31
040/220	18		18	1.476	1.474	1.475	166.82
040/220	27		27	0.550	0.552	0.551	93.48
040/220	36		36	0.344	0.346	0.345	78.04
040/220	54		54	0.100	0.102	0.101	34.27

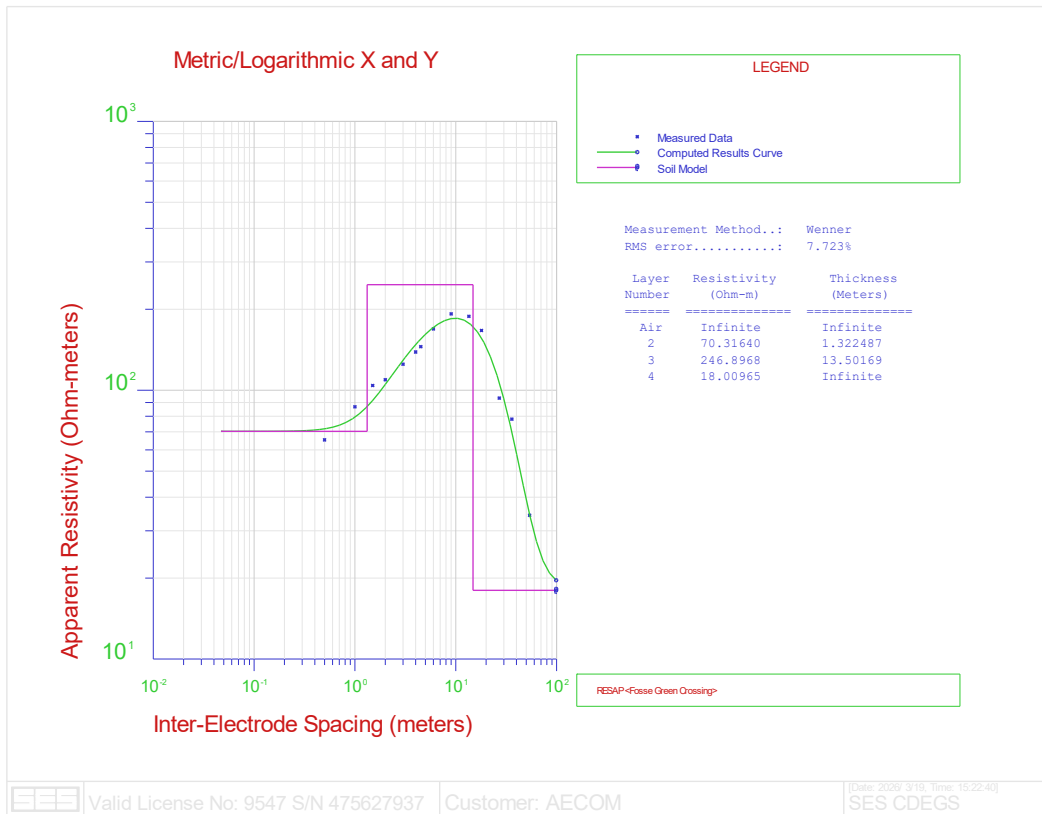

Figure 22 – SR3 developed soil model

Appendix B Soil Resistivity Ground Investigation Report



1 Croft Stairs
Newcastle upon Tyne
NE1 2HG

Our Ref: 260305. L.001

27 March 2026

██████████,
Technical Director, Environment,
Aecom Limited,
3 Rivergate,
Redcliffe,
Bristol,
BS1 6NA.

Re: Soil Resistivity Ground Investigation – Fosse Green Solar Farm, Navenby, Lincolnshire

Dear ██████████,

Roberts Environmental Limited (“**REL**”) were instructed by Aecom Ltd (“**the Client**”) to undertake Soil Resistivity testing across an area of agricultural land where it is proposed to construct a solar farm and associated infrastructure, including buried cables (“**the Services**”). The proposed solar farm is named Fosse Green Solar Farm and is to be located across land to the east of Navenby in Lincolnshire (“**the Property**”).

We have been provided the following client reference data in relation to this project.

Aecom Reference Information	
Purchase Order:	#UK1764740
Project Code:	60700987
Task Code:	2.03

The field works were undertaken to obtain data to assess potential effects from earthing installations on a below ground hydrocarbon fuel pipeline that transects the site. The objective was to measure the soil resistivity at three locations on the site.

Please find the following documents included with this letter report.

- Enclosure 1: Site Location Plan
- Enclosure 2: Soil Resistivity Test Location Plans
- Enclosure 3: Test Results Data Tables
- Enclosure 4: Graphical Representation of Results
- Enclosure 5: Calibration Certificates



Executive Summary

A programme of soil resistivity (SR) testing was carried out at Fosse Green Solar Farm, Navenby, Lincolnshire. The data is required for background information to assess potential effects from solar farm earthing installations on a major fuel pipeline that crosses the site.

Three expanding Wenner arrays (SR1 – SR3) were completed for the testing programme, with test locations shown on the test location plan in **Enclosure 2**. The soil resistivity data are presented in Tables 1 – 3 in **Enclosure 3**. Logarithmic graphs of the resistivity data are given in **Enclosure 4**.

Site Details

Location	The site is located off Green Man Road, approximately one kilometre west of the A15 Sleaford Road and one kilometre east of Navenby in Lincolnshire (Enclosure 1).
NGR / Postcode	TF00495864 / LN5 0AY
Geology (BGS 2026)	Superficial: None recorded. Bedrock: Lincolnshire Limestone Formation (Middle Jurassic 170 - 168 Ma).
Survey Method	Soil resistivity testing

Soil Resistivity Method

Soil resistivity is a geophysical method that measures variations in subsurface electrical properties, by applying small electrical currents across arrays of electrodes inserted into the ground.

Traditional resistivity surveys are carried out using four equally spaced electrodes, set out in a standard configuration Wenner Array as outlined in BS EN 50522 and IEEE Std 81-2012. Readings are obtained by passing a low frequency electrical current across the two outer electrodes, with the potential difference measured across the inner two electrodes (Figure 1). The resistivity system automatically calculates the ground resistance by dividing the measured voltage by the current.

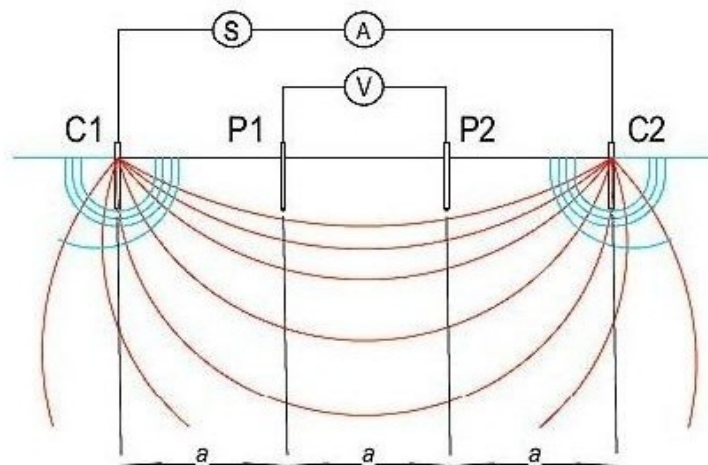

Figure 1 - Standard soil resistivity test with four electrode Wenner array showing a schematic illustration of current flow lines.

The Wenner model assumes measurements are made at a point on the surface, but this relationship can break down if the electrode is pushed too far into the ground. In optimum conditions the depth of the electrode should be less than 5% of the electrode spacing.

The resultant resistance readings are converted into apparent resistivity values (ρ_a) that represent the average ground resistivity between the electrodes. The geometric correction factor for converting the resistance readings into resistivity values depends on the configuration of electrodes used for the test measurement. The apparent resistivity for a Wenner configuration is given by the equation presented on the following page:

$$P_a = 2\pi aR$$

P_a = Apparent resistivity in Ohm-metres

a = Electrode spacing in metres

R = Resistance in Ohms

Models of vertical variations in ground resistivity are obtained by using an expanding electrode array centred on the same reference point, known as an electrical sounding. The depth penetration increases directly in proportion to the spacing between the electrodes, provided the ground is reasonably homogenous. The apparent resistivity is measured at various electrode spacings, with the array centred on the same measurement point.

Site Testing Procedure

The soil resistivity testing was carried out on 12th March 2026 by Sumo Geo Surveys Limited supervised by Roberts Environmental Ltd. The tests were undertaken in high winds and cloudy weather conditions with intermittent sunshine and a maximum temperature of 12°C. Ground conditions were generally dry during the survey.

A Megger DET 2/2 Digital Earth Tester was used for the testing; a calibration certificate is attached in **Enclosure 5**. The system delivers a low frequency AC current to the electrodes. An operating frequency of 128 Hz was set on a variable current setting, to reduce potential interference from 50 Hz mains electricity.

The testing was carried out on three crop fields located on either side of Green Man Road, Test Location Plans are included in **Enclosure 2**. The test locations (SR1 – SR3) were agreed on site with the client, positioned and aligned to optimise the arrays to the space available, and ensure they were not close to the fuel pipeline. SR1 and SR3 were positioned on newly seeded crop fields on the south side of the road. SR2 was in a vacant field on the north side, with very soft ground conditions from previous deep ploughing.



Plate 1 Testing in progress at SR1 viewed in a south-west direction



Plate 2 Soil resistivity testing in progress at SR2



Plate 3 Soil resistivity testing in progress at SR3

The testing was carried out in accordance with specifications outlined in BS EN 50522, involving four equally spaced electrodes set out in a straight line, expanding Wenner Array centred on the test position. Readings were taken at electrode spacings of 0.5, 1, 1.5, 2, 3, 4, 4.5, 6, 9, 13.5, 18, 27, 36 and 54 metres, subject to available access. All three arrays achieved the maximum desired electrode spacing of 54 metres, with orientations of 075/255 for SR1; 170/350 for SR2 and 040/220 for SR3. A minimum of two resistance readings (R1 & R2) were taken at each electrode spacing to check data repeatability.

Summary of Results

The results of a programme of soil resistivity testing at Fosse Freen Solar Farm are presented in Tables 1 - 3, in **Enclosure 3**. Data was acquired at the three test locations (SR1 – SR3) . The tables list the array orientation; electrode spacing; nominal testing depth and electrical resistance in Ohms at each electrode spacing. The two resistance readings (R1 and R2) measured at each electrode spacing on both arrays generally display good repeatability, well within acceptable tolerance limits. The tables also present the average resistance and apparent resistivity in Ohmmetres for each electrode spacing. Logarithmic graphs of apparent resistivity against electrode spacing are presented for each location in **Enclosure 4** together with preliminary inversion models.

The results displayed variability between the three test locations, with resistivity ranges of 230 – 132 Ohm-metres for SR1 and 192 – 34 Ohm-metres for SR3. Higher resistivities were recorded at SR2 within a range of 451 – 108 Ohm-metres. The variation in resistivity is most pronounced in the first eight readings between 0.5 – 6.0 metres electrode spacing, with some occurring at wider spacings. This suggests the disparity may be caused by lithological variations in the upper ground levels, which is supported by the preliminary inversion models.

No clear pattern of resistivity with depth is seen at SR1, with readings fluctuating up and down within the resistivity range. At the other two locations, there are initial increases in resistivity with depth for the first four readings at SR2 and the first eight at SR3, then progressively decreasing resistivity with depth for the remaining readings at wider spacings.

The differences in resistivity between SR2 from the field on the north of Green Man Road, compared to SR1 and SR3 in the fields on the south side are of uncertain cause. The logarithmic graphic plots indicate the data is of reasonable quality, with RMS values at or below 5%. According to the BGS viewer, the resistivity variations are not readily explained by differences in site geology. All three fields are apparently underlain by the same limestone formation, with no superficial deposits having been recorded in this area. Without any borehole data from the site, it is not possible to speculate further on the composition or variability of the actual strata present below the test locations.

Conclusions

Three linear expanding Wenner arrays were carried out on Fosse Green Solar farm to provide background data. The results are presented in tabular form in **Enclosure 3**. Logarithmic plots of the data are displayed in **Enclosure 4**.

It should be noted that ground resistivity can vary seasonally and may also be modified by the introduction of new fill material during any future construction operations. The results may not be valid if future remediation / earthworks of the ground is carried out on the site.

Yours sincerely,

Mike Hay MSc BSc (Hons)

Director

For and on behalf of Roberts Environmental

Tel: 

Mob: 

ENCLOSURE 1. Site Location Plan

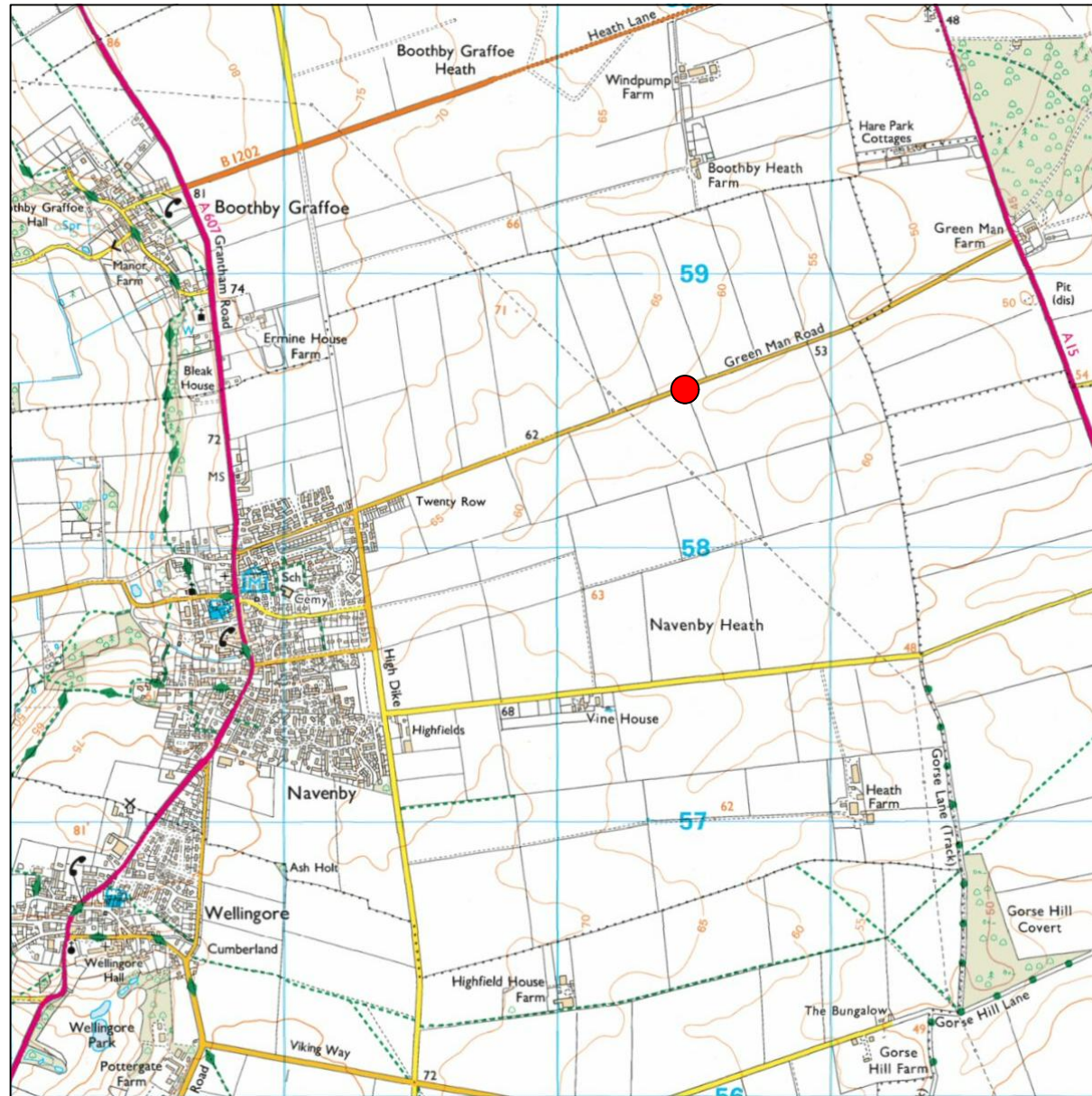

 Site Location

Reproduced from Ordnance Survey's 1:25 000 map of 1998 with the permission of the controller of Her Majesty's Stationery Office. Crown Copyright reserved. Licence No: 100018665



Title: Site Location Diagram

Client: AECOM

Project: 260305 Fosse Green Solar Farm, Navenby - Soil Resistivity Testing



Scale:  1:25000 @ A3

Fig No: 01

ENCLOSURE 2. Soil Resistivity Test Location Plans

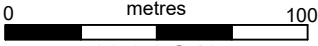
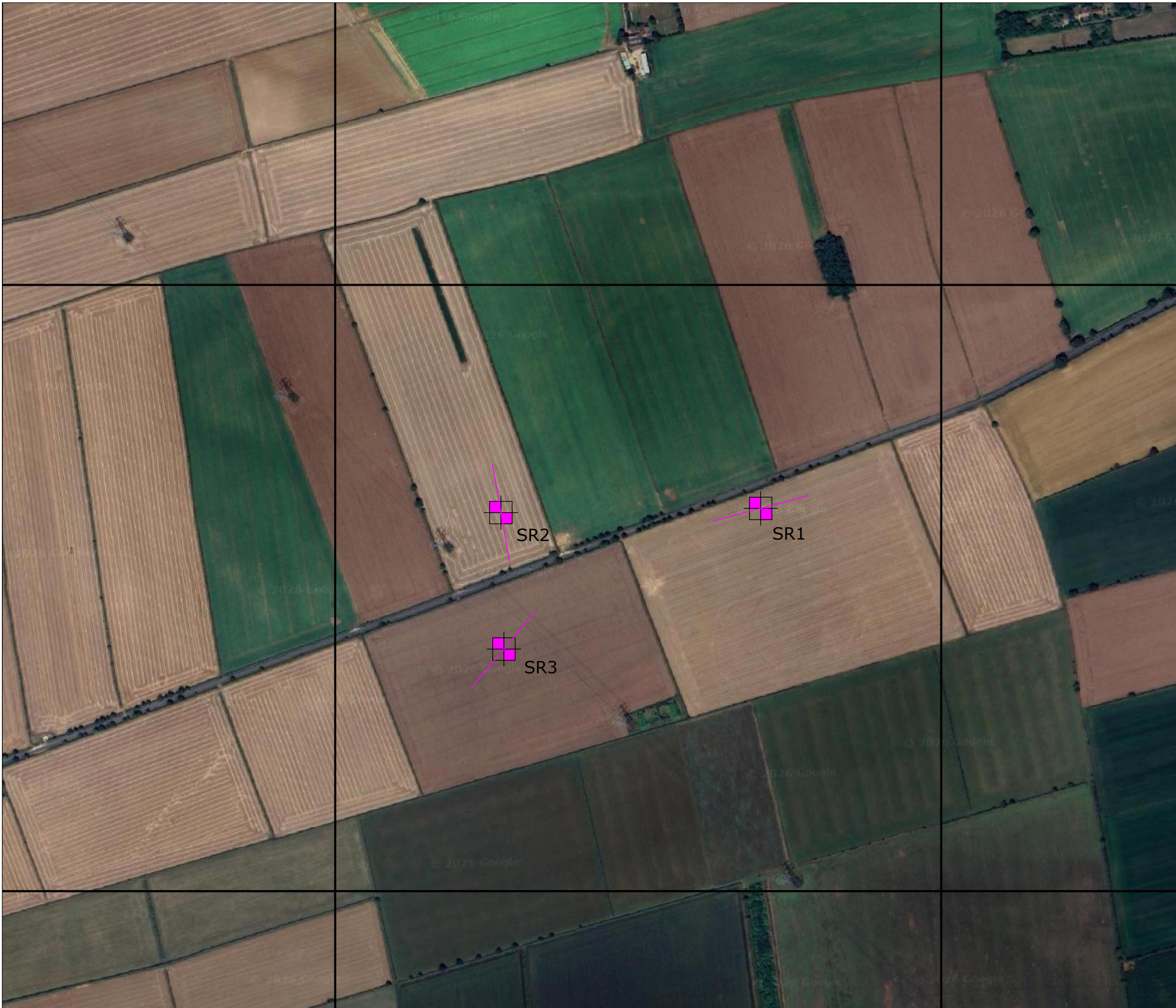

KEY

 Soil Resistivity Test Location



Title: Soil Resistivity Tests Overview Plan

Client: AECOM

Project: 260305 Fosse Green Solar Farm,
Navenby - Soil Resistivity Testing

Scale: 0 metres 300
1:6000 @ A3

Fig No: 02



KEY

 Soil Resistivity Test Location



Title: Soil Resistivity Tests Location Plan

Client: AECOM

Project: 260305 Fosse Green Solar Farm, Navenby - Soil Resistivity Testing

Scale: 0 metres 150
1:3000 @ A3

Fig No: 03

ENCLOSURE 3. Test Results Tables

ENCLOSURE 4. Logarithmic Graphs of Apparent Soil Resistivity vs Electrode Spacing SR1 – SR3 with Preliminary Inversion Models

Figure A12 – Fosse Green Solar Farm
 Logarithmic Graph of Apparent Soil Resistivity vs Electrode Spacing & Preliminary Inversion Model - Location SR12

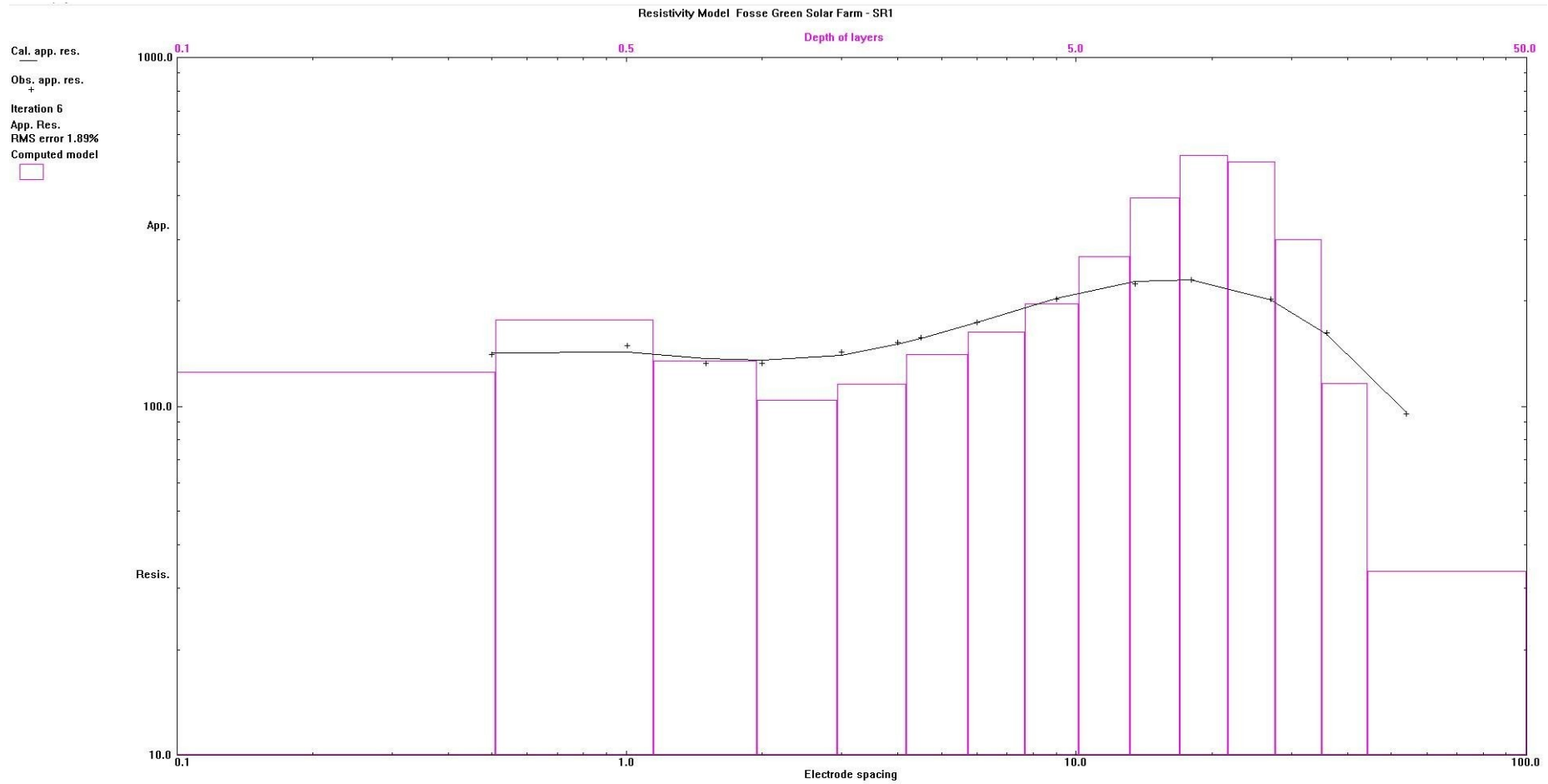

Figure A12 – Fosse Green Solar Farm

Logarithmic Graph of Apparent Soil Resistivity vs Electrode Spacing & Preliminary Inversion Model - Location SR13

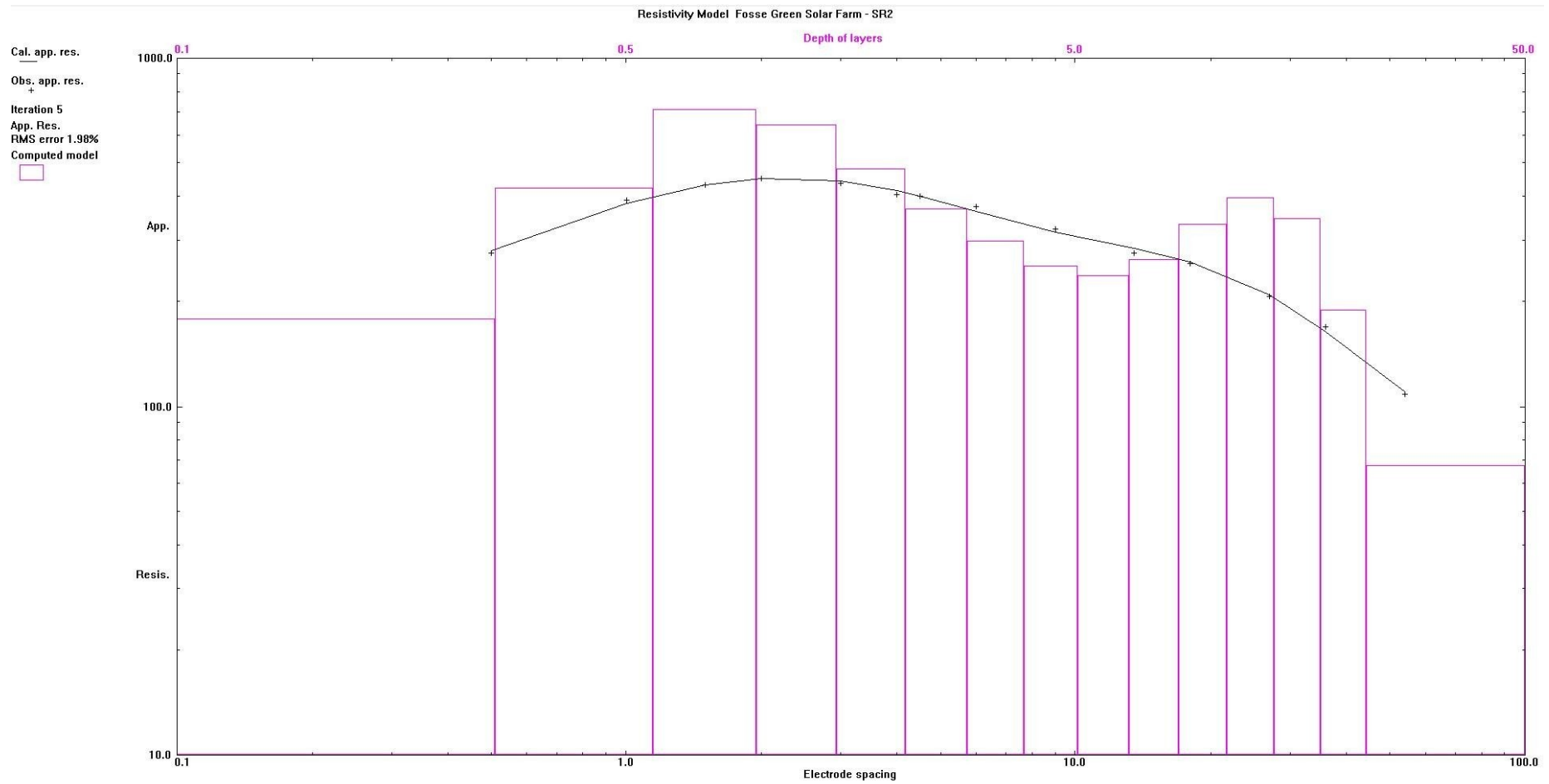
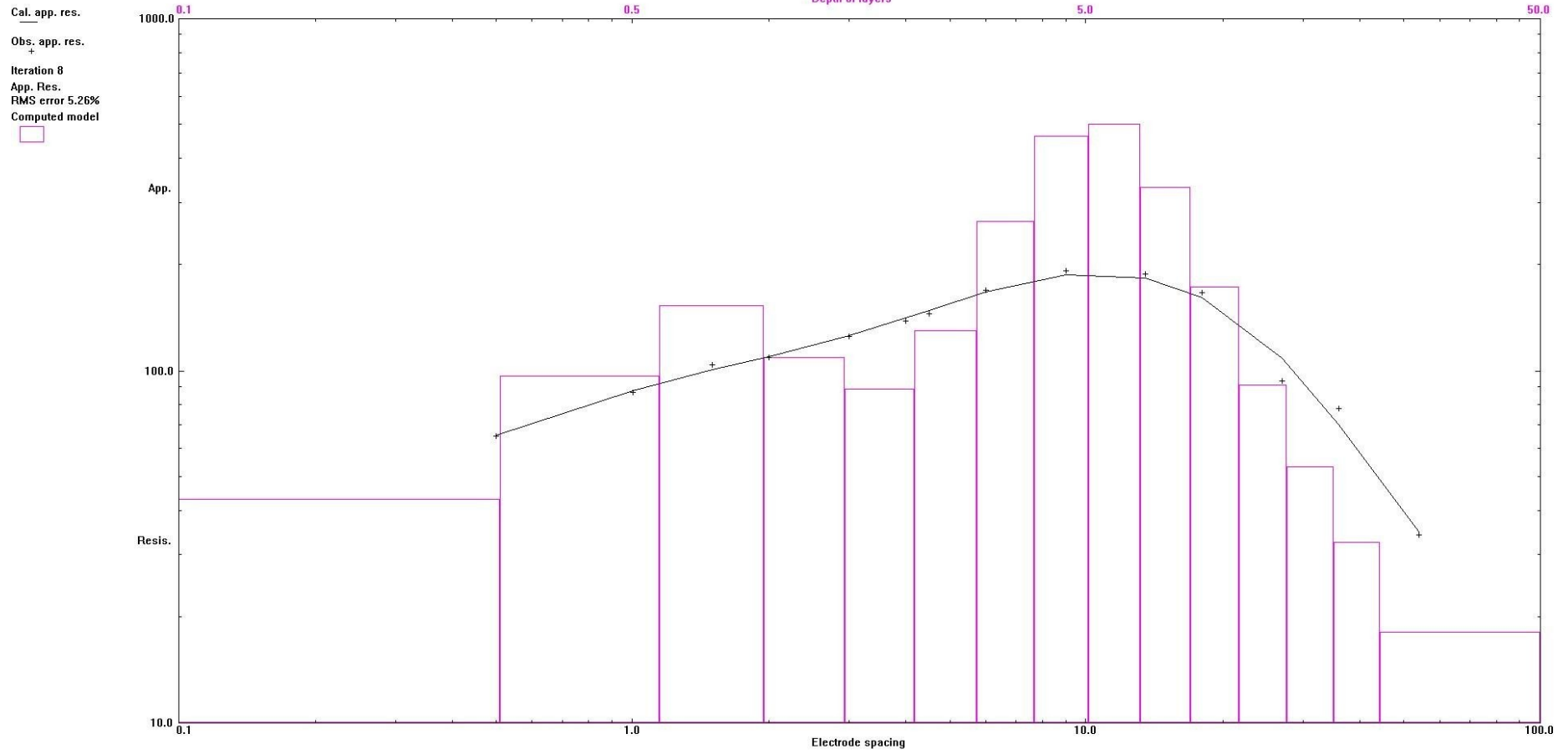

Figure A13 – Fosse Green Solar Farm

Logarithmic Graph of Apparent Soil Resistivity vs Electrode Spacing & Preliminary Inversion Model - Location SR13

Resistivity Model Fosse Green Solar Farm - SR3



ENCLOSURE 5. Megger DET 2/2 Auto Earth Tester Certificate of Calibration

CERTIFICATE OF CALIBRATION

QC 20/F

BS EN ISO 9001:2015 Cert. No. FS 09953

Certificate Number

H2601175

Page 1 of 2



Micro Precision (Midlands) Ltd
Watt House, Pensnett Estate
Kingswinford,
West Midlands
DY6 7YD
Tel: 01384 401132
e-mail: uk-contact@microprecision.com

CUSTOMER : SUMO GEOPHYSICS LTD
VINEYARD HOUSE, UPPER HOOK ROAD
WORCESTERSHIRE
UPTON ON SEVERN
WR8 0SA

Order No. :

Customer Ref. : None

Engineer
Location

Calibration Information

Instrument Type : MEGGER DET2/2 AUTO EARTH TESTER
System ID : WED680

Serial Number : 1005M459920

Job Number :

Ambient Conditions

Temperature : 21°C ± 2°C
Relative Humidity : 50% ± 20%

Calibration Date : 03/02/2026

Cal Due Date : 03/02/2027

Calibrated Under a Quality Management System Assessed By The BSI to BS EN ISO 9001:2015. The equipment used is traceable to National Standards (N.P.L.). ISO10012 : 2003 is used for guidance.

This instrument has been tested to the tolerances specified in the Procedure Number : 1270

CONDITION PRIOR TO CALIBRATION - A :- No Adjustment Required

Overall result after calibration : PASS
Calibration status : COMPLETED

THE CALIBRATION STATUS WILL SHOW:

TERMINATED - if the procedure was prematurely terminated;
COMPLETED - if the procedure was completed without abnormal conditions

Instrument Description	STANDARDS USED FOR CALIBRATION			Cal Period
	Asset Number	Certificate Number	Cal. Date	Wk
RES BLK RESISTOR BLOCK	Q42	H2504698	23/04/2025	52
1040 Decade Box	Q298	5523631032166622	15/09/2025	52

Authorised By :

CERTIFIED THAT THE WHOLE CALIBRATION DETAILED HEREON HAVE BEEN INSPECTED AND TESTED IN ACCORDANCE WITH THE CONDITIONS AND REQUIREMENTS OF THE CONTRACT OR PURCHASE ORDER AND UNLESS OTHERWISE STATED CONFORM IN ALL RESPECTS TO THE SPECIFICATION(S) DRAWING(S) RELEVANT THERETO, AND THE MANUFACTURERS ORIGINAL STANDARDS WHERE AVAILABLE.

CERTIFICATE OF CALIBRATION

BS EN ISO 9001:2015 Cert. No. FS 09953

Calibration Date
03/02/2026

Certificate Number
H2601175

Page 2 of 2

Test Title	Tolerance	Applied Value	Reading	Pass / Fail
EARTH RESISTANCE				
1 Ohm	7mR	1.000R	0.996R	PASS
10 Ohm	70mR	10.00R	10.00R	PASS
100 Ohm	700mR	100.0R	100.0R	PASS
500 Ohm	4.5R	0.500kR	0.501kR	PASS
1.0 KOhm	7R	1.000kR	1.001kR	PASS
5.0 Kohm	45R	5.00kR	4.99kR	PASS
10.0 Kohm	70R	10.00kR	10.04kR	PASS
15.0 Kohm	95R	15.00kR	15.05kR	PASS
19.0 Kohm	115R	19.00kR	19.05kR	PASS

Instrument was allowed to stabilise before calibration.

***** *END OF TEST DATA* *****

Appendix C Finaline Crossing Specification

1. Fosse Green Energy circuit Voltage
 - a. The Fosse Green Energy circuit is to be rated at 400 kV_{RMS} (Line – Line).

2. Fosse Green Energy circuit Current
 - a. The Fosse Green Energy circuit is to be rated to 240 MW or 347 A (Line – Line).

3. Modelled fault parameters
 - a. Ground return current associated with a phase – earth fault on 4ZM OHL is assumed to be 11.56 kA.
 - b. The ground return current was injected into the earthing system of NGET tower designation 4ZM525.
 - c. Touch Potentials for the safety Voltage assessment on Finaline during a fault scenario assumes the fault on the OHL is cleared within 0.2 s.

4. Fosse Green Energy circuit cable size and specification
 - a. The grid connection circuit is assumed to comprise of three Aluminium 1200 mm² (conductor cross sectional area) 400 kV cables.
 - b. The grid connection circuit cables are to be to IEC 62067.
 - c. Final cable characteristics to align with the characteristics below to ensure that the calculated current density values, presented in this document, are as accurate as possible. This assessment is to be reviewed against the final cable selection to ensure the limitations in this document are satisfied.

Component Name	Conductor Properties				Insulation Properties			
	Inner Radius (m)	Outer Radius (m)	Relative Resistivity	Relative Permeability	Outer Radius (m)	Resistivity (Ωm)	Relative Permittivity	Relative Permeability
Core	0	0.019544	1.273	1	0.052044	1E+12	2.3	1
Sheath	0.052044	0.054944	2.09819	1	0.060944	1E+10	7	1

5. Fosse Green Energy circuit phase arrangement
 - a. The Fosse Green Energy cables are to be laid in trefoil arrangement up to 15m from the nearest jointing bay either side of the Finaline crossing.
 - b. The Fosse Green Energy cables are to be laid flat arrangement at joint bays.

6. Clearance between Finaline and Fosse Green Energy circuit joint bays
 - a. Joint bays associated with the Fosse Green Energy circuit are not to be situated within land 100 metres either side of Finaline.

7. Fosse Green Energy circuit joint bay earthing resistance
 - a. Joint bays associated with the Fosse Green Energy circuit are have a maximum resistance of 10 Ω .

8. Finaline and Fosse Green Energy circuit crossing angle
 - a. The Fosse Green Energy circuit is to cross Finaline at 90°. This 90° angle is to be maintained for a minimum of 5 m either side of the crossing.

9. Finaline and Fosse Green Energy circuit minimum separation
 - a. The Fosse Green Energy circuit to Finaline separation is to be a minimum of 600 mm.

10. Fosse Green Energy circuit
 - a. The Fosse Green Energy circuit assumed to be laid in ducts. Concrete encasement is acceptable.

11. Separation between Fosse Green Energy circuit and existing NGET OHL
 - a. The minimum separation between the Fosse Green Energy circuit and the outermost conductor of the existing NGET OHL is to be 30 m.

Appendix D Finaline Crossing Indicative Drawings

LEGEND

	PE CABLE DUCT
	HDPE COMMUNICATION DUCT
	RED MARKER STRIP OR STEEL PLATES
	YELLOW MARKER WARNING TAPE

A = XLPE APPROVED DUCT, SDR=11, DIAMETER TBC
B = XLPE APPROVED DUCT, SDR=11, DIAMETER TBC

- NOTES
- DRAWING IS FOR INDICATIVE PURPOSE ONLY.
 - DO NOT SCALE FROM THIS DRAWING USE ONLY PRINTED DIMENSIONS.
 - ALL DIMENSIONS ARE IN MILLIMETERS, ALL CHAINAGES, LEVELS AND CO-ORDINATES ARE IN METERS UNLESS DEFINED OTHERWISE.
 - NO EXCAVATION SHALL COMMENCE UNTIL THE CONTRACTOR HAS CONSULTED UP TO DATE SERVICES DRAWINGS AND CARRIED OUT AN ELECTROMAGNETIC LOCATOR (EML) SCAN.
 - HAND DIG ONLY WITHIN 500mm OF EXISTING SERVICES.
 - NO JOINT BAYS WILL BE LOCATED WITHIN 100M OF THE PIPELINE.
 - CROSSING WILL BE PERFORMED WITH A CROSSING ANGLE OF 90 DEGREES. THIS ALIGNMENT WILL BE MAINTAINED FOR 5M EITHER SIDE OF THE PIPELINE.
 - CROSSING FINALINE THE CABLES WILL PASS UNDER THE PIPELINE WITH A MINIMUM SEPARATION OF 600MM.

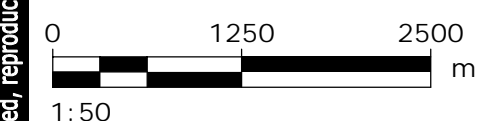
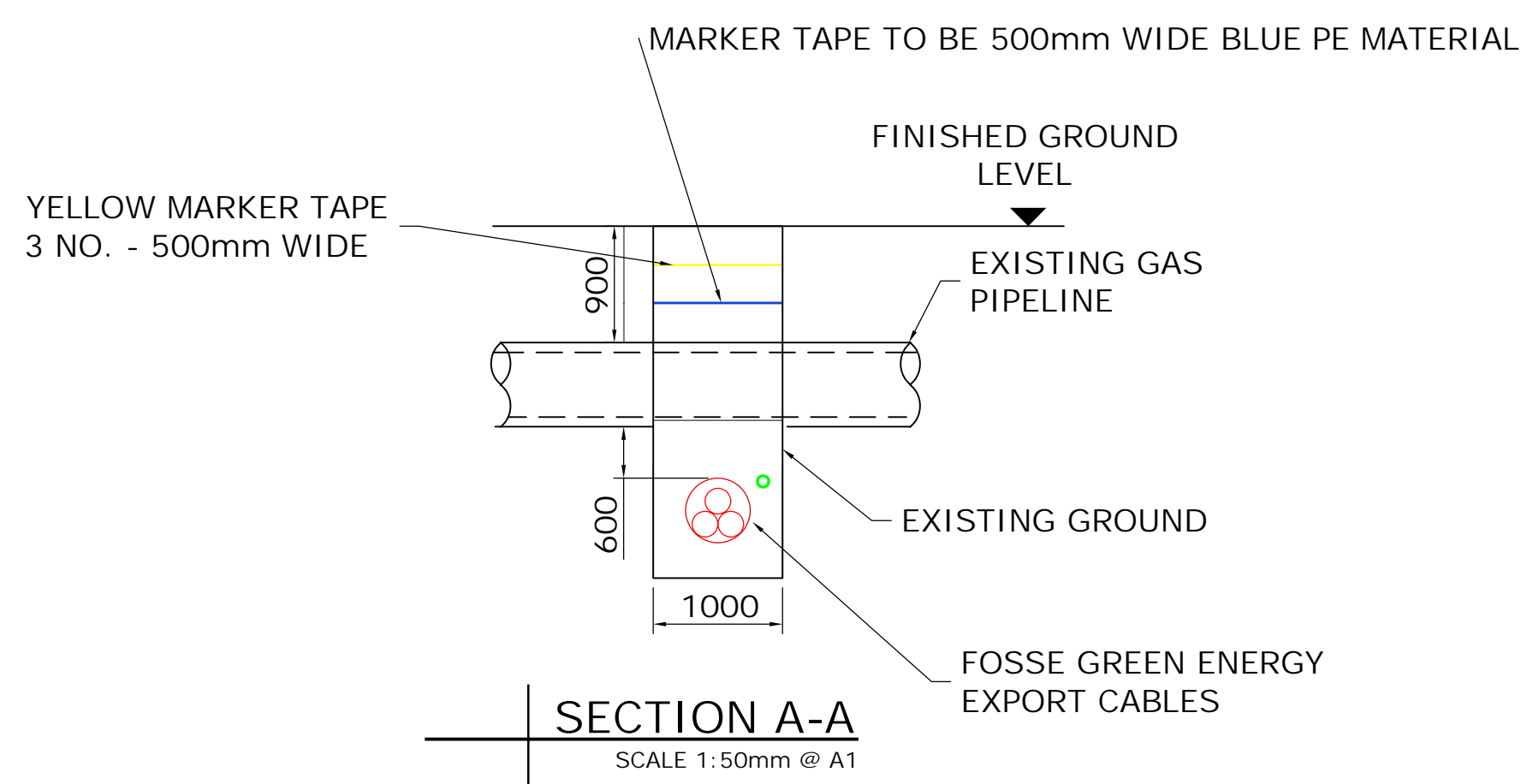
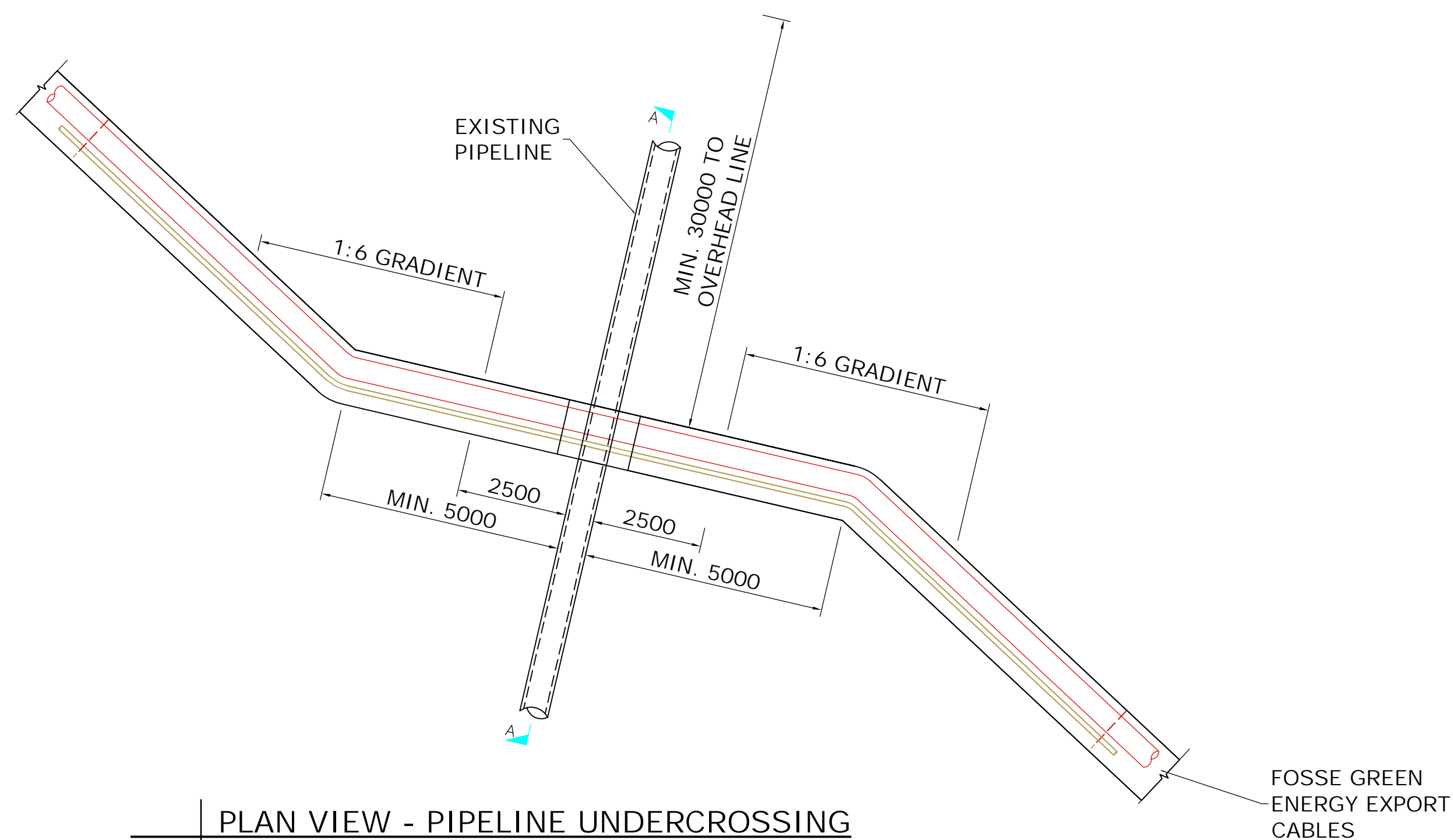

LEGISLATION
Regulation 5(2)(a) Infrastructure Planning (Applications: Prescribed Forms and Procedure) Regulations 2009.

ISSUE PURPOSE
DCO Submission
PROJECT NUMBER
60700987

FIGURE TITLE
400KV PIPELINE CROSSING
FIGURE NUMBER
Figure 1-1
DOCUMENT REFERENCE
EN010154/APP/X.X

400kV Cable Characteristics								
Component Name	Conductor Properties				Insulation Properties			
	Inner Radius (m)	Outer Radius (m)	Relative Resistivity	Relative Permeability	Outer Radius (m)	Resistivity (Ωm)	Relative Permittivity	Relative Permeability
Core	0	0.0195	1.2730	1	0.0520	1.0000E+12	2.3000	1
Sheath	0.0520	0.0549	2.0982	1	0.0609	1.0000E+10	7	1

NOT FOR CONSTRUCTION

FOR INFORMATION ONLY

This drawing has been prepared for the use of AECOM's client. It may not be used, modified, reproduced or relied upon by third parties, except as agreed by AECOM or as required by law. AECOM accepts no responsibility and denies any liability whatsoever, to any party that uses or relies on this drawing without AECOM's express written consent. Do not scale this document. All measurements must be obtained from the stated dimensions.